

L'Édition of université paris-saclay winter 2021

Year

2021

Country

France

Section and theme

Research – JWST

Page

19

Issue

17

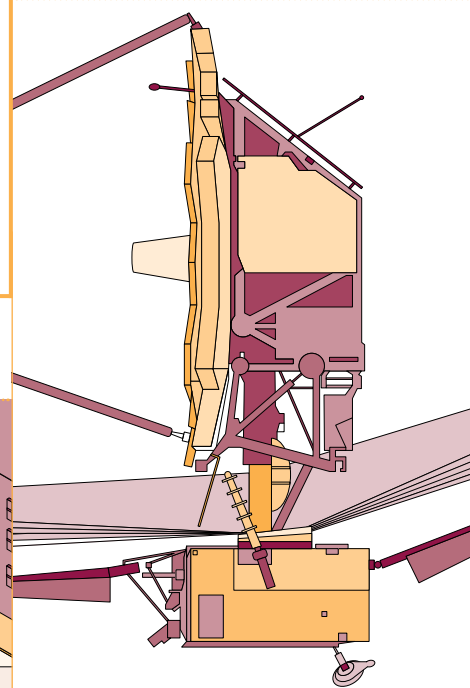

Section

Formation

Page

04

Section and theme

Business & Innovation – Autonomous Vehicles

Page

14

Title

THE INTERNATIONAL OUTLOOK CONCERNING EDUCATION

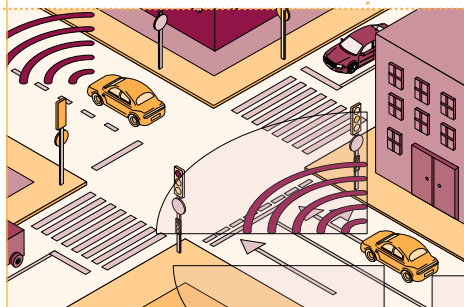

Section

Teaching, Learning

Page

06

Section and theme

Research – Mental Health

Page

16

Title

INCREASING INITIATIVES LINKING ARTS, SCIENCE AND TECHNOLOGY

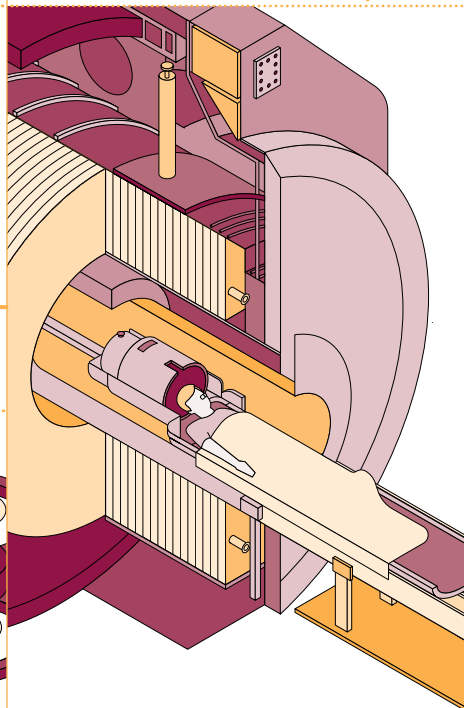

Section

Seen from abroad

Page

23

Title

FRANCE CLIMBS INTERNATIONAL RANKINGS

Section and theme

Research – UAV

Page

08

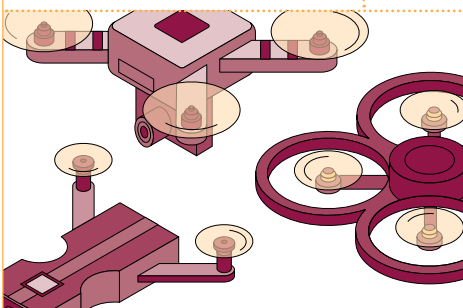

Section

Campus life

Page

24

Title

FACILITIES AT THE DISPOSAL OF STUDENTS AND STAFF

Section and theme

Research – Precision medicine
in oncology

Page

11

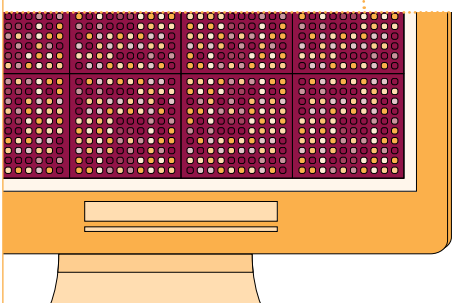

université PARIS-SACLAY

Address

Bâtiment Breguet – 3 rue Joliot-Curie 91190 Gif-sur-Yvette – France

Website

www.universite-paris-saclay.fr



RESEARCHERS



© Institut d'Optique Graduate School

Pierre Chavel, from the Charles Fabry Laboratory (LCF – Univ. Paris-Saclay, CNRS, Institut d'Optique Graduate School), has been awarded the **Robert E. Hopkins Leadership Award** from the Optical Society for his promotion of optics throughout Europe.

Thibault Damour, professor at the IHES, is the winner of the **Balzan Prize 2021** awarded by the Balzan Prize International Foundation for his work on the theoretical prediction of gravitational wave signals produced by binary systems of compact objects.

Dominique Desbois, from the Public Economics Laboratory (ECOPUB – Univ. Paris-Saclay, INRAE, AgroParisTech), is the winner of the **2021 Vermeil Medal of the French Academy of Agriculture**. His work focuses on the micro-economics of agricultural production.

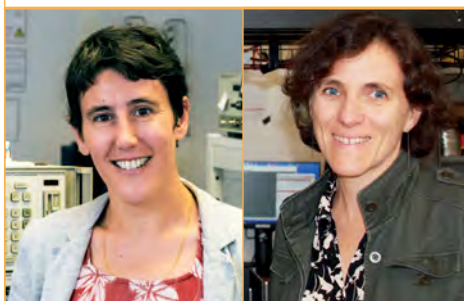

© Laurent Thion/Ecliptique/ © SD/UPSaclay
CNRS Photothèque

Seven researchers from Université Paris-Saclay have been rewarded by the French Academy of Sciences: **Lou Barreau**, from the Orsay Institute of Molecular Sciences (ISMO – Univ. Paris-Saclay, CNRS) received the **Louis Armand Prize 2021**; **Antoine Browaeys**, from the Charles Fabry Laboratory (LCF – Univ. Paris-Saclay, CNRS, Institut d'Optique Graduate School), was awarded the **Alfred Verdaguer Prize 2021 – Institute of France Foundation**; **Étienne Fouvry**, from the Orsay Mathematics Laboratory (LMO – Univ. Paris-Saclay, CNRS), was awarded the **Sophie Germain Prize 2021 – Institute of France Foundation**; **Julie Grollier**, from the CNRS/Thales joint physics unit (UMPhy – Univ. Paris-Saclay, CNRS), received the **Irène Joliot-Curie 2021 Prize** in the category Woman Scientist of the Year; **Rebeca Ribeiro-Palau**, from the Centre for Nanoscience and Nanotechnology (C2N – Univ. Paris-Saclay, CNRS, Univ. de Paris), is the winner of the **Ernest Déchelle 2021 Prize**; **Marie-Hélène Schune**, from the Physics of the Two Infinities – Irène Joliot-Curie Laboratory

(IJCLab – Univ. Paris-Saclay, Univ. de Paris, CNRS) was awarded the **State Funded Prize 2021**; **Pascale Senellart-Mardon**, from the Centre for Nanoscience and Nanotechnology (C2N – Univ. Paris-Saclay, CNRS, Univ. de Paris) is the winner of the **Mergier-Bourdeix Grand Prize 2021**.

STUDENTS

Anne-Lise Boixel, from the Biology and Risk Management in Agriculture laboratory (BIOGER – Univ. Paris-Saclay, INRAE), **Laëtitia Cardona**, from the Biotechnological Processes for the Environment laboratory (PROSE – Univ. Paris-Saclay, INRAE), and **Margot Leclère**, from the Agronomy laboratory (Univ. Paris-Saclay, AgroParisTech, INRAE), received the **2021 Dufrenoy silver medal from the French Academy of Agriculture** for their thesis work.

Anne-Gaëlle Goubet, a doctoral student in the Tumour Immunology and Cancer Immunotherapy Laboratory (ITIC – Univ. Paris-Saclay, Gustave Roussy, Inserm), is the winner of the **L'Oréal-Unesco Foundation's Young Talent Award "For Women in Science"**. She is working on the treatment of bladder cancer by immunotherapy.

Audrey Chatain, **Oriane Della-Negra**, **Solène Laville** and **Ilias Naji** are the winners of the **2021 solemn prize of the Chancellery of the Universities of Paris** for their thesis carried out respectively at the Laboratory of Atmospheres, Environments and Space Observations (LATMOS – Univ. Paris-Saclay, UVSQ, CNRS, Sorbonne Univ.), at the Genoscope (Univ. Paris-Saclay, Univ. d'Évry, CEA, CNRS), at the Research Centre for Epidemiology and Population Health (CESP – Univ. Paris-Saclay, UVSQ, Inserm) and at the Professions, Institutions, Temporalities laboratory (PRINTEMPS - Univ. Paris-Saclay, UVSQ, CNRS).

Hana Valenta is the winner of the **2021 thesis prize of the French Chemical Society**, Île-de-France section, in «Theoretical, physical and analytical chemistry», for her thesis carried out at the Institute of Physical Chemistry (ICP – Univ. Paris-Saclay, CNRS).



The **iGEM GO Paris-Saclay 2021 team**, made up of a dozen students, most of whom are affiliated with the Faculty of Sciences of Université Paris-Saclay, won the **gold medal in the iGEM 2021 competition** for their EndoSeek project on the detection of endometriosis, and a **special iGEM Grand Prize** for the project with the best inclusion.

PROJECTS / COMPANIES

The **HUXI BioSciences project**, resulting from the work of the teams of Sylvia Cohen-Kaminsky from the Pulmonary Hypertension: Physiopathology and New Therapies laboratory (HPPIT – Univ. Paris-Saclay, Inserm), Mouad Alami from the Biomolecules: Design, Isolation, Synthesis Laboratory (BioCIS – Univ. Paris-Saclay, CNRS, Univ. Cergy-Pontoise), and Alain Pruvost, head of the SMArt-MS platform of the Pharmacology and Immunoanalysis Department (SPI – Univ. Paris-Saclay, CEA, INRAE), is the winner of the **i-Lab 2021 innovation competition**. This project aims to develop and validate in vivo a new drug candidate for the treatment of pulmonary arterial hypertension (PAH).



The start-up **It's Brain**, whose attentional cognitive diagnostic tool MindPulse is the result of research carried out at the Paris-Saclay Neuroscience Institute (Neuro-PSI – Univ. Paris-Saclay, CNRS), is the winner of the **i-Lab 2021 competition**.

EDITOR'S LETTER



© UPSaclay

One of the most exciting scientific events of the end of the year is undoubtedly the launch into orbit of the largest space observatory ever deployed: the James Webb Space Telescope (JWST). With its high-resolution imager on board, the telescope will allow us to explore even the most distant exoplanets up close. You will discover its potential in the science section of this issue of *L'Édition*, as well as the laboratories at the Faculty of Sciences of Université Paris-Saclay and the CEA Paris-Saclay which, under the aegis of CNES, have developed and calibrated it.

Also on the agenda for this issue: other news based on leading publications from the University's laboratories, such as drones, their reliability and the evolution of air law, which echo the overview we offer on the subject of intelligent, connected and autonomous vehicles.

In health, another area of excellence for the University, you will discover new immunotherapy-based therapeutic options for the treatment of cancers, as well as the potential of MRI to improve our understanding of certain mental pathologies, with a goal that involves all of our medical and pharmaceutical communities, as well as those working in chemistry, physics, mathematics, engineering and computer science: to care and continue to improve the care we provide.

In these fields and in all others, international collaborations are clearly essential and very stimulating. This is something we wanted to highlight in an article devoted to the increasing internationalisation of our educational courses, teams and programmes. With the French Presidency of the European Union, to which we will contribute throughout the entire semester, we will have the chance to give you new insights with European universities, major research infrastructures and disruptive innovation.

As this winter issue of the Université Paris-Saclay journal is published at the end of 2021, allow me, on behalf of the University, its students and staff, to send you my best wishes for 2022. I look forward to seeing you at Paris-Saclay, in Europe and anywhere else in the world, where higher education and research are the driving forces of humanism, citizenship and the future.

Sylvie Retailleau,
President of Université Paris-Saclay



Title

The international outlook concerning education at Université Paris-Saclay



© Jacob Khrist / Université Paris-Saclay

Promoting intercultural experiences and furthering the skills of its staff and students, and increasing its attractiveness and helping to forge a common identity for all its stakeholders are some of the major objectives of the strategy for an international outlook promoted by Université Paris-Saclay. After a difficult year in which the health crisis has badly affected travel abroad, it is clear that today initiatives in this area are gaining ever increasing ground.

With 38% of international students enrolled on Master courses and 45% on PhDs, as well as 185 French students spending their first semester of 2021/2022 abroad, there is no doubt that the international outlook of Université Paris-Saclay is going from strength to strength. A key objective in terms of strategy, this desire for international openness is not just limited to increased mobility, but extends to all aspects of teaching.

Ever more Master's degrees taught in English

A telltale sign – 18 Master 1 and 37 Master 2 courses are taught entirely in English. Designed to offer training in line with major international standards, these Master's degrees are increasingly popular today. "They have the advantage not only of preparing students for the world of research where the majority of publications are written in English, but also of offering international career opportunities," explains Olivier Bos, who is responsible for the Master 1 in Economics. Launched in 2020 and supported by ENS Paris-Saclay and the Jean Monnet Faculty, this very selective Master (700 applications for 50 places in Master 2) is mostly made up of French students at the moment. "We're sure that the share of international students will increase over the years along with the attractiveness of our University," adds Matthieu Crozet, who is responsible for the Master 2.

Opening up Université Paris-Saclay to international students

Université Paris-Saclay also offers other international study programmes to increase its

openness to international students further. These include the Erasmus Mundus Masters. "Designed and delivered jointly within the framework of an international partnership between several higher education institutions in different countries, the strengths of these Master's programmes are that they attract students from all over the world and allow them to spend two periods of study in two countries different from their country of residence and, at the end of the programme, to be awarded a joint degree or multiple degrees," explains Eva Renouf, who is responsible for the SERP+ Master. Supported by Université Paris-Saclay in conjunction with universities in Italy, Poland, Portugal and nineteen other associated partners, the SERP+ Master (which focuses on chemistry, physical chemistry and materials science) has welcomed over thirty different nationalities of students since its creation in 2008. Ola Alayan, a student from Lebanon currently studying for a SERP+ Master 2, is one of these. "With fellow students from all over the world, a semester of study in Italy and the quality of the teaching – everything in this Master's programme is as good as I expected when I enrolled!" French students, such as Coline Thevenard, are equally delighted by this international aspect. She



is a first year student studying for the new LASCALA (Large Scale Accelerators and Lasers) Erasmus Mundus Master. *“It’s this openness to the world, which for me is inseparable from a scientific approach that persuaded me to join this Master course.”*

Opportunities for periods spent abroad at Université Paris-Saclay

Université Paris-Saclay is committed to increasing its attractiveness, it is also working to increase the number of intercultural experiences for its students, particularly in Europe. Europe is the perfect environment for trying out the values of inclusiveness, sustainable development and European citizenship promoted by the University.

Université Paris-Saclay has partnerships with the Ludwig-Maximilian University of Munich (Germany), Lund University (Sweden), the University of Porto (Portugal) and the University of Szeged (Hungary) within the framework of the *European University Alliance for Global Health* (EUGLOH) project for the creation of a pilot European university concentrating on the issue of global health. As part of the Erasmus+ course, it is now possible for students, from undergraduate to doctoral level, to benefit from services and funding which facilitate short or long periods abroad in one of the member universities of EUGLOH. Also, thanks to the digitalisation initiative launched during the pandemic, more than 90 online courses have also been developed and are offered to students at the five universities.

More generally, *“The Erasmus+ course grants exemption from tuition fees and a monthly maintenance allowance,”* explains Julie Hérisson, who directs the Mobility Centre at the Department for International and European Relations at Université Paris-Saclay

To promote the mobility of its students outside the European Union, Université Paris-Saclay benefits from international credit mobility (ICM) programmes to universities in ten non-European countries, as well as collaborative programmes with North America (BCI, MICEFA or TASSEP exchange programmes).

Training academic staff and researchers in taking an international perspective

In addition to these schemes for students, Université Paris-Saclay is also aiming to provide the best possible support for its academic staff and researchers. The latter can benefit from thirteen strategic partnership projects set up by the University with at least two stakeholders from two different countries with

whom innovative teaching practices can be developed and shared.

“Another factor, which has long been underused by lecturers and staff is the Erasmus+ programme which offers them short-term travel opportunities to deliver courses or to benefit from training or sharing good practice,” adds Julie Hérisson.

For those for whom language is a barrier, Université Paris-Saclay offers the chance to study one or more of the fourteen foreign languages taught at its various sites. To help prepare their courses within the context of English as a Medium of Instruction (EMI), lecturers can take a look at the Captivate! workshops organised remotely by the Academic Writing Centre of Université Paris-Saclay. *“By focusing the learning on storytelling, the aim of this series of four workshops is to help lecturers teach more effectively within an EMI context, but above all to give them the tools to gradually prepare their lessons independently,”* explains Divya Mahdavan, the Academic Writing Centre’s coordinator.

International summer schools for all

Students, PhD students, engineers and researchers from Université Paris-Saclay or from other French or international universities can all take part in international Summer Schools covering many subject areas. It is an opportunity for everyone to enjoy a rich cultural and social programme as part of an international group.

<https://www.universite-paris-saclay.fr/collaborations/international>

Title

When acquiring information skills becomes a game

To know how to identify, decipher and reference information, to assess the reliability of information sources and to avoid plagiarism... These are some of the concepts and skills covered by the new Small Private Online Course (SPOC) Society for Information and Digital Media, which will be available from January 2022 on the eCampus platform.

It is aimed at all of the University’s undergraduate students and its goal is to improve their research of documents, combat misinformation, develop critical thinking skills and develop a methodology and work ethic.

Designed as a fun, interactive, investigative journey where participants assist a detective, the SPOC consists of five independent sessions, each lasting two to three hours, on a variety of topics which do not require specialist knowledge. Black holes, artistic plagiarism, the Chernobyl nuclear disaster, gender studies, artificial intelligence – each session is validated by a specific badge and the SPOC can be completed in its entirety or module by module.

<https://ecole-universitaire-paris-saclay.fr/actualites/le-jeu-enquete-du-spoc-societe-de-linformation-et-medias-numeriques>

Title

Health professionals – think about continuing education!

Versatile and across scientific disciplines, the continuing health education courses offered by the Faculties of Medicine, Pharmacy, Sciences and Sports Science at Université Paris-Saclay include a wide range of training courses and diploma or qualification courses ranging from public health to nanotechnologies applied to health, R&D and regulatory matters. Some are included in the Continuing Professional Development (CPD) scheme.

The Faculty of Medicine at Université Paris-Saclay offers over 100 University Diplomas (UD) and Inter-University Diplomas (IUD), 9 Masters, 5 short courses and 9 CPD courses. The Faculty of Pharmacy has 8 UD and IUDs, 2 short courses leading to qualifications, 1 CPD course, 5 professional degree courses and 22 Master courses. The Faculty of Science offers seven UD in optometry, as well as a professional degree in optics and a Master in vision science. Three UD covering aspects of human movement sciences applied to health, a professional degree in fitness and eleven Master courses are offered by the Faculty of Sports Science.

There is something for everyone, whether it is to consolidate or increase your professional skills, obtain a qualification, develop your career or develop yourself personally.

https://www.medecine.universite-paris-saclay.fr/sites/default/files/2021-05/Livret-FC-sante_web.pdf



Title

Université Paris-Saclay is increasing its initiatives linking arts, science and technology

© CreARThaton

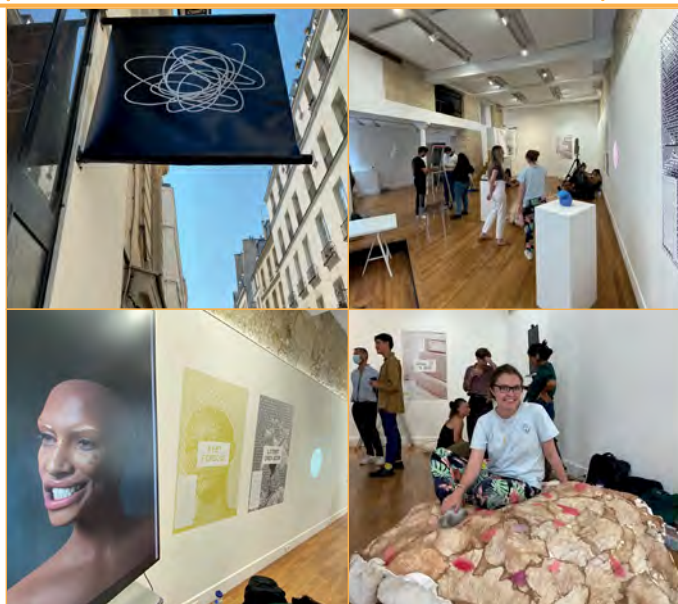

As teaching and learning are also synonymous with creativity, Université Paris-Saclay is rolling out an original programme to combine scientific knowledge with artistic experience.

The first CreARThaton, which brought together art, design and computer science in a hackathon-style summer school, took place on 23 to 27 August on the initiative of Université Paris-Saclay, Inria and the Societies association. This event attracted 32 students (Master and PhD) studying artificial intelligence and human-machine interaction (HMI), and students from various art and design schools in Paris to the FabLab Digiscope. At the end, each multidisciplinary team exhibited their “creative, interactive and intelligent” pieces in the Galerie Joseph in Paris. Wendy Mackay, co-organiser of the programme and a researcher in HMI at the Interdisciplinary Laboratory of

Digital Sciences (LISN – Univ. Paris-Saclay, CNRS, CentraleSupélec, Inria) explains: “By facing up to the challenge of their different perspectives, the students discovered new ways of working. It was a great success. We’ve already been asked if we’re going to repeat the event in 2022.”

An artist residency programme launched in April 2021 with the Societies association is also offering the opportunity for two artists per year to meet scientists. They are largely working at the Institute for the Diversity, Ecology and Evolution of the Living World (IDEEV – Univ. Paris-Saclay, CNRS, AgroParisTech, IRD) and at Inria Saclay. “It’s a unique opportunity for these artists to circulate around the whole campus and create knowledge networks between the various key players in the area,” points out Jeanne Turpault, who directs the association’s Contemporary art and research centre.

Once again this year, the research-creation platform, Scène de Recherche-ENS Paris-Saclay,

is offering a very attractive 2021/2022 programme of performances and training courses taking place in its auditorium or off-site which combine the performing and visual arts, basic sciences, and engineering and social sciences. The events include *Cosa Mentale*, *La Fabrique des méduses* (The jellyfish Factory), *Eurydice*, *Une expérience du noir* (An experience of the dark)... In addition, there was the 6th CURIOSITas festival, put on in collaboration with the Diagonale Paris-Saclay, which was all about awakening the senses. Co-created by artists and scientists from the University, the installations, exhibitions and performances gave pride of place to visual, tactile, sound and olfactory sensations. These were exhibited from 9 to 26 November 2021 in eight locations across the Ile-de-France.

<https://creartathon.com/>
<https://ens-paris-saclay.fr/scene-de-recherche>
<https://www.curiositas.fr/>

Title

“Sciences for all”: secondary school students in laboratories



© Université Paris-Saclay

From 29 November to 3 December 2021, Université Paris-Saclay organised the third “Sciences pour tous” (Sciences for All) action, in partnership with the association Sciences Essonne. Based on the model of the action initiated by the CEA since 2016, “Sciences for all”

offers internships to 14-15 year old secondary school students from schools in the REP+ (Priority Education Network) to discover the workplace in a laboratory. The selected students are young people interested in science who cannot find an internship due to a lack of contacts in the business world. During five days, some sixty students from the Sonia Delaunay, Pablo Neruda and Jean Vilar secondary schools in Grigny, and Paul Eluard in Sainte-Geneviève-des-Bois, discovered the laboratories of Université Paris-Saclay and CEA Paris-Saclay, their cutting-edge equipment and the research being carried out there, as well as teamwork and the various jobs that a laboratory entails.

They also carried out small manipulations and took part in experiments. A joint presentation in the presence of the researchers who hosted them and personalities from the academic world and the local authorities concluded their rich week of training.

Illustrations
right-hand page
and page 22:
Thomas Hayman



Title

Safer, More Reliable and More Agile Drones

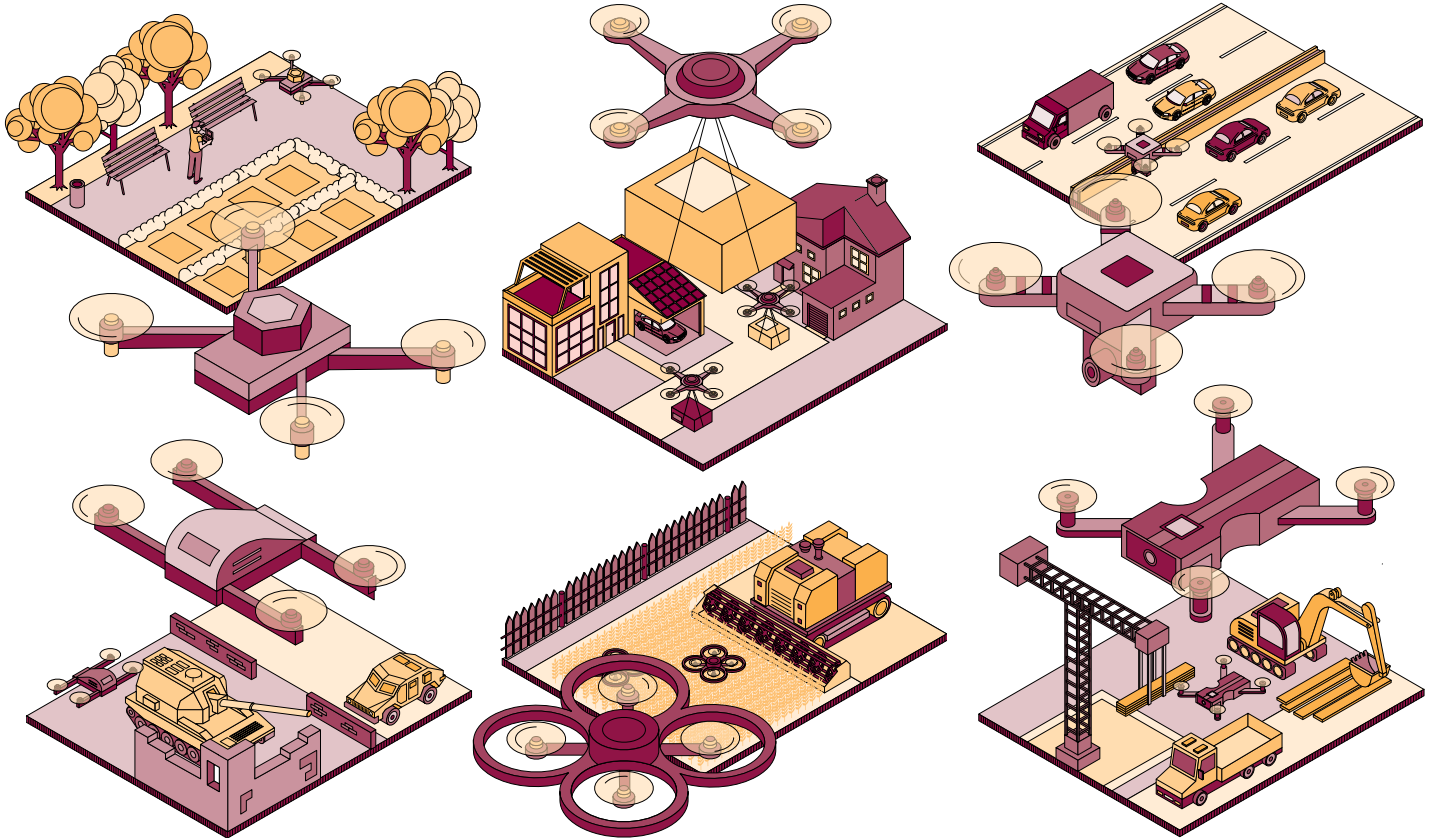

When used alone or several at once, professional civilian drones have demonstrated a largely underused potential. With drone use being in full flight, researchers are looking at how they may improve the reliability, security, and adaptability of these machines.

You can often hear it buzzing long before you can see it. Whether it has fixed or rotating wings, drones of all sizes have seen a rapid rise over the past few years. These Unmanned Aerial Vehicles (UAV), which can be controlled using a radio control or a smartphone, and were initially for military use, have now taken over civil society. With sensors and HD cameras, drones have flooded the hobbyist market. At the same time, their use in professional contexts has grown, whether it is to assist people, deliver parcels, watch over fields, or even inspect facilities. This expansion, however, is still limited. *“Although there has been an explosion of intentions to use them, the allocation of flight licences by the French Civil Aviation Authority (DGAC) remains very slow,”* explains Reda Nouacer, from the Integration of systems and technology laboratory (LIST – Université

Paris-Saclay, CEA). The security aspect is also a factor.

This licence is the much-wanted ‘golden ticket’ for operators. Without it, their mission cannot take place. In order to receive it, the applicant must first declare and detail the planned flight conditions (points of departure and arrival, schedule, the context in which the drone will fly, statistics-based meteorological conditions, etc.). *“These aspects are also used when choosing the drone, the sensors, the required battery life, etc. Yet, the licence, once issued, is only valid for that specific mission. An operator cannot really buy as many drones as they have missions to carry out,”* says Reda Nouacer. The challenge is therefore to adapt the mechanics of a drone to a new mission quickly and affordably, without calling into question the reliability of its certification or slowing down the process of obtaining a flight licence.

When Modulation Becomes Easy

Within the COMP4DRONES project, Reda Nouacer and his colleagues are working to develop an embedded architecture solution and a core set of reusable and enabling tools and technologies to be made available to SMEs to help them rapidly adapt their drones. Forty-

eight academic and industrial partners are involved in this European Union funded project (ECSEL JU).

They have taken inspiration from the modularity used in the automotive and avionics industries to develop agile customisation. *“We are reusing an already-authorized module. The modular architecture that we have developed does not change the structure nor the design of the system. This ensures that the allocated licence remains valid and saves time.”* They have identified a reference architecture, which means uniform and standardised interfaces, protocols, and integration methodology. In particular, they compared open-source autopilots (the flight software that is generally provided by the manufacturer) and identified their similarities. *“We identified function-related building blocks, typical composition and the architecture pattern.”* In other words, the connecting mechanics between blocks. *“It’s the equivalent of an integration and development protocol.”*

This type of suggested adaptation will make life easier for SMEs. *“We can artificially increase their skills by providing a tool that will help them to develop the electronics and software that is to be integrated.”* For drones, these elements are particularly important for their real-time detection

of the environment. As their payload is limited, not everything can be embedded straightaway. *“This is what we’re adding to the system to allow it to make safe and autonomous decisions. The tools that we are proposing have the added benefit of having already been tested.”* Tools such as Papyrus modeler, which is used for model-based engineering and that generates code for robotics, Amesim by SIEMENS, which simulates the motor in context, and the S3D software, which analyses system performance.

The project, which will finish in September 2022, also includes the roll-out of 11 demonstrations for use in five fields (transport, construction, logistics, inspection and surveillance, the latter for the agriculture industry in particular). All of them are currently being tested. *“The project is reaching its growth and technology evaluation phase,”* announces Reda Nouacer.

The Art of Tolerating Flaws

We now know that improving the reliability of UAVs is a major area of concern. Nevertheless, like any other machine, a drone can suffer from failures. Among the elements on which it relies, is the flight control system, which ensures the stability and control of the drone. This is the purpose of the flaw tolerance diagnosis and control methods that are developed by the SIAM (Signal, Image, Automatism) team at the Computer Science, Bioinformatics and Complex Systems Laboratory (IBISC–Univ. Paris-Saclay, Univ. d’Évry). Lydie Nouvelière, Dalil Ichalal and their colleagues design algorithms that can estimate the presence of flaws and isolate them, calculate control laws that are tolerant of them and analyse their robustness. Ultimately, the models they develop help to define a strategy for maintaining the system.

Firstly, the researchers analyse flight dynamics, which differ according to the UAV in question. This involves mathematically expressing the structure and behaviour of the UAV over time (speed, position, angles, orientation, etc.). It is often necessary to simplify equations. *“We extract a simplified synthesis model to use it more easily while still trying to keep a certain realism,”* explains Dalil Ichalal. To develop it, researchers use either predefined models—models with six degrees of freedom, forces and moments, dynamic coefficients—or AI-derived data. Other models—linear with variable parameters, for example—apply more specifically to situations where the drone’s geometry changes during the mission. This is the case for a drone whose mass and inertia vary with the delivery of the package, or for a drone equipped with a mobile arm. To go even further, the team is now looking to combine methods: *“We will supplement the model with artificial intelligence*

to estimate the simplifications made initially,” emphasises Lydie Nouvelière.

Then, they have to calculate a nominal flight control law. *“We study its scope of application to verify that it is valid and capable of operating a trajectory,”* explains Dalil Ichalal. They also study other issues that may arise during a drone’s flight, such as gales or obstacles (birds and pylons). *“These external and unpredictable disruptions are unknown inputs for the system. They define a disrupted model and control law.”* With a solid control law, the drone can estimate the disruption, and balance out its trajectory in real time. Disruptions are sometimes internal, such as communication loss due to a malfunctioning sensor. This is a ‘flaw’. *“A flaw is abnormal functioning of the system. It is different from a disruption due to its permanent nature,”* explains Dalil Ichalal. The most frequent flaws are linked to wear and tear on the actuators (jacks). Other are sporadic, such as loose contacts. *“There are also system flaws, such as fractures, which changes the drone’s aerodynamism.”*

Once the flaw has been diagnosed, the system will determine the category into which it should be classed, in order to isolate it. Yet, in engineering, it is widespread practice to duplicate components or essential functions. Speed, for example, is measured using several, distinct types of sensors, and the sensitivity of measurements of a given flaw generates flaw characteristic patterns. *“It is then a case of determining if the flaw is severe or not, and if we can reconfigure the control law to take the flaw into account. We can, for example, replace a sensor with an ‘observer’, which is an algorithm that can predict and estimate the missing measurements,”* remarks Lydie Nouvelière. This is ‘flaw tolerant control’. Nevertheless, not all flaws are tolerable: the system must calculate to see if the feasibility conditions of the trajectory are still met, and to replan it if necessary.

Management of the Fleet in Question

While it is critical to guarantee the flight security of the drone, operating it can be even more complicated when it means using a fleet of drones over an area that is to be explored, while searching for targets (debris, people, vehicles), whether they are static or not. The challenge, therefore, is to ensure they evolve jointly and without danger, so that they are capable of remotely notifying the presence of targets of interest and that they can differentiate them from areas without these targets. *“Emergency services can reach areas faster or a patrol can avoid going into a combat area,”* says Hélène Piet-Lahanier, from the Information Processing and Systems Department (DTIS) at ONERA

Palaiseau. She and her colleague, Sylvain Bertrand, frequently collaborate with Cristina Stoica Maniu and Michel Kieffer’s teams, from the Laboratory of Signals and Systems (L2S–Université Paris-Saclay, CNRS, Centrale-Supélec) on the issue of correct co-operation of a fleet. Several aspects are decisive: communication, management, and flight effectiveness.

This co-operation can be seen in three ways. It can be centralised with one, unique operator, and therefore the entire fleet will share its gathered information with this operator. The operator will define a strategy that can be applied to all the drones, and when needed, reallocate missions using an optimisation algorithm. Reliable and constant communication is essential. Conversely, it can be a decentralised system, wherein each drone can conduct its mission without concerning itself about its neighbouring drones. A middle approach, that of a distributed system, sees that drones that are close to one another exchange collected information, depending on their possible means of communication. *“The information is then sent to other drones outside the first emitting circle, and this creates local communication clusters,”* describes Hélène Piet-Lahanier, who works on this type of method. It is undeniably a timesaver but is limited if the area is spread out and littered with obstacles. *“The drones cannot exchange information between one another for a long while.”*

Implementing a mobility strategy that maximises high-quality data collection and that avoids collision is crucial. Certain elements, such as *“the known presence of an obstacle, hypotheses about target movement and their absence in certain areas for specific reason,”* can partially influence this. The type of UAV used determines another. *“It is about defining a coherent trajectory. For example, a fixed-wing drone cannot hover, nor can it do a hairpin bed, unlike a quadcopter.”* After this comes estimation algorithm definition. *“It determines where one or more targets are present, and where none are present.”* The crux of the problem is coordinating drone flights to ensure the whole area of interest is swept, and to get a clear point of view. *“The area where the target may be located must be visualised from all angles to ensure detection, even in the presence of a cloaking device. If the target is mobile, it is more complex, as this visualisation must be simultaneous, and more restrictive in terms of fleet management.”* Drones therefore will draw a specific map of the location of objects of interest, which is added to over time, as they explore.

If Retreating is the Solution

Errors in assessment cannot be excluded. *“Sometimes the drone does not have the right*



angle of view, or sensor; to remove any ambiguity, and mistakes a decoy for a target. It is by cross-referencing information collected by other drones that we can discriminate it.” In the same way, if a piece of collected information does not fit the general trends, it means that the drone has a problem. “Thanks to co-operation and exchange between drones, we can find the incoherent drone,” and thus it will be reallocated to a different mission. “We will allocate it to an area where it will not be a danger and where information is not decisive.” If it is no longer physically able to follow the movement, it will carry out a diagnosis of its possibilities of evolution, and according to the result, will land in emergency or open its parachute.

Successfully retreating one or several drones from a fleet without any problems is the area of focus for Cristina Stoica Maniu, from the L2S, and her colleagues, who use predictive control. This advance control, which is most used in automation, is based on a mathematical model that can anticipate the behaviour of the fleet, which is comparable to a multi-agent system working in a defined area. Researchers have recently developed a new decentralised algorithm for the deployment and reconfiguration of a drone formation during a mission. The algorithm constantly marks out the zone in the form of a polygon tessellation, Voronoi cells, each of which has a localised drone in the Chebyshev centre, the centre of the largest enclosed circle in a polygon. This tessellation changes with the movement of the drones, and if a drone leaves the fleet, the drones will align themselves again on a new centre to avoid any collision. “The algorithm calculates the new distribution of Voronoi cells and Chebyshev centres to reorganise the configuration of the drone fleet.” Once the drone has retreated, the others will restart their initial task.

Teams from IBISC, ONERA and L2S are currently optimising their algorithms and implementing them in drones, to conduct experiments within their respective drone flight arena. “After simulations, it is the only way to experience real conditions and expected performances,” concludes Lydie Nouvelière.

Publications

- Radermacher A., et al. Designing Drone Systems with Papyrus for Robotics. In Proceedings of the 2021 Drone Systems Engineering and Rapid Simulation and Performance Evaluation: Methods and Tools Proceedings, (2021).
- Bouzgou K., et al. PD Sliding Mode Controller Based Decoupled Aerial Manipulation. ICINCO (2020).
- Abouselima E., et al., Robust Actuator Fault Diagnosis for LPV systems: Application to Quadrotor. American Control Conference, (2021).
- Ibbenthal J., et al. Bounded-error target

localization and tracking using a fleet of UAVs, *Automatica*, vol. 132, 109209, (2021).

- Chevet T., et al. Decentralized MPC for UAVs Formation Deployment and Reconfiguration with Multiple Outgoing Agents. *J Intell Robot Syst* 97, (2020).

Title

Can drones and the law take off together?

Although the law has suffered from a certain delay in the field of UAVs, it has been trying to make up for this over the past few years.

Initially, the reference legal text in the field of international civil aviation, the Chicago Convention of 1944, only had one article dedicated to UAVs. Article 8 forbids UAV to fly over the territory of a foreign country, except with special authorisation. Generally, UAV flights across a border are always marginal. “At the time, we were preparing to end World War II, and the many possibilities of drones had yet to be considered,” says Vincent Correia, professor in public law at the Jean Monnet Faculty (Law, Economics and Management). “Additionally, these UAVs have a multitude of means of propulsion and weights and did not fall into any categories outlined in traditional aviation law (small aircraft, microlights, commercial aeroplanes, helicopters).”

Following several incidents linked to drones nearing international airports, the International Civil Aviation Organization (ICAO) took up the issue. “The Annex 2 of the Chicago Convention was amended in 2012 to include the definition of UAV, as well as the Annex 13 on post-accident investigation.” At the same time, under Regulation 216/2008, the European Union Aviation Safety Agency (EASA) intervened for drones weighing more than 150 kg, which are far from being the majority.

Faced with European shortcomings, national regulations took up the task, and France is leading the way. In 2012, the French Civil Aviation Authority (DGAC) adopted two decrees to provide guidance in the classification of civil airborne drones into categories of model aircraft, and remote-controlled and non-remote-controlled aircraft. These categories combined maximum take-off mass, operating conditions, and pilot capability. In 2015, France adopted two new decrees to replace those from 2012.

“The law was fine, but perhaps insufficiently detailed, and there was especially a problem in the application of the norm.” These new decrees added more restrictions and increased information and training obligations for pilots. They also distinguished between remote-controlled aircraft and autonomous aircraft, and outlined rules for using autonomous and semi-autonomous systems. “We had, for the first time, defining elements as to what an autonomous flight was.”

European Regulation 2018/1139, which was adopted in 2018, expanded EASA’s competences. It dropped the 150 kg limit and adopted a phased approach, comparable to the French rules. Adopted in 2019, the Implementing Regulation 2019/947 distinguished between three categories of flight: open (low risk), specific (medium risk) and certified (high risk), correlating flight scenarios and UAV mass. It specified rules for open category UAV regarding training obligations for pilots, including sometimes having to sit an exam. Delegated Regulation 2019/945 set out the design and manufacturing requirements for UAVs to be operated.

European and national supervisory authorities have taken on the responsibility to uphold these rules. In France, it is the DGAC, the gendarmerie and the police who have this role. “National monitoring is applied according to criteria that are gradually being harmonised at European level. European and national law supplement one another, and in the event of incompatibility, the former takes precedence over the latter.” Regarding data and privacy protection, traditional instruments are applied (the French Civil Code, right to respect for private and family life, French Penal Code, etc.), which are usually sufficient.

Automation of UAVs does nevertheless pose regulatory problems: in the event of a dispute, who is responsible if a teleoperator is absent? The manufacturer of the drone or the public authority that authorised the autonomous flight? “For the time being, the technology is not regarded as mature and the approach of the authorities remains very cautious.” Will drones one day be able to fly in unsegregated airspace, once reserved for civil aviation and authorised flights? “It will first be necessary to consider the already complex task of air traffic controllers and to allay the fears of the populations overflown by these aircraft.”

Title

Working towards personalised cancer treatment

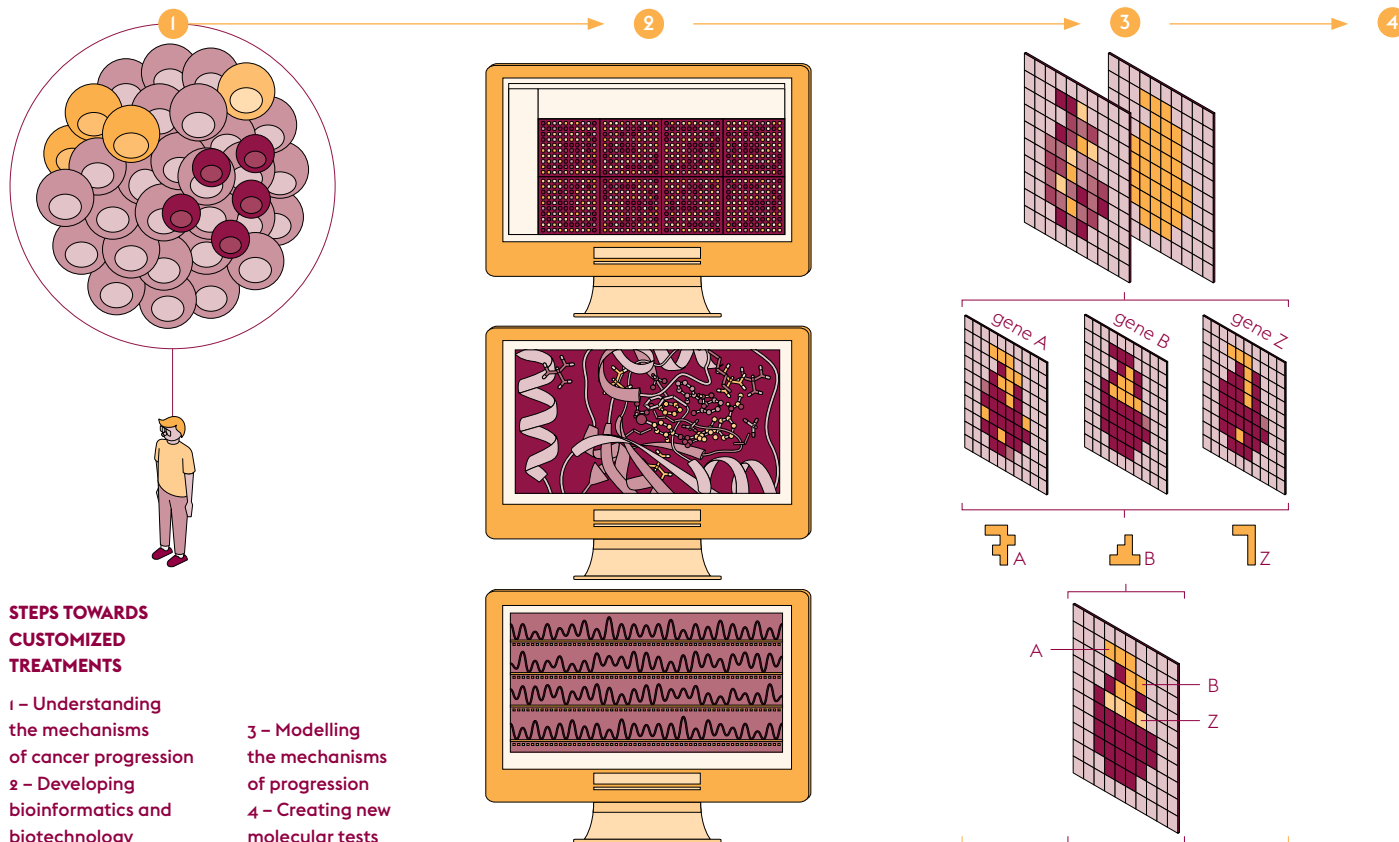

The evolution of cancer screening as well as the therapeutic interventions provided have gone hand in hand with advances in science. Before the study of radioactivity or discoveries in pharmacology gave rise to radiotherapy and chemotherapy, the first surgical treatments were limited to localized and less advanced cancers. Today, advances in genomics and immunology are paving the way for treatment to be tailored to the specific needs of each patient.

Each cancer is unique and the genetic mechanisms specific to each patient influence the cancer's appearance, evolution and response to various treatments. Based on this, the PRISM research centre, which is accredited as a national centre for precision medicine in oncology, is involved in the development of new practices and more effective treatments.

Modelling cancer

Fabrice André, who is in charge of the Molecular Predictors and New Targets in Oncology

unit (PMNCO – Univ. Paris-Saclay, Gustave Roussy, Inserm) and joint manager of PRISM, sums up its objective. “Today, the sequencing of all genes leads to the identification of therapeutic targets for approximately 20% of cancer cases. We want to increase the number of patients receiving the most appropriate treatment as soon as possible.” To extend these therapeutic possibilities to as many people as possible, PRISM models each cancer using artificial intelligence to structure and interpret data from large-scale clinical trials. As Fabrice André explains, “This identity card establishes the specific molecular and cellular mechanisms of each patient. These markers predict the risk of recurrence, the effectiveness of different treatments and the occurrence of adverse effects.” And if resistance occurs, this information quickly leads to other treatments.

In the PMNCO laboratory, Fabrice André's team has already identified markers that include, for example, a mutation deregulating the expression of the *TRIB3* gene, which induces resistance to certain drugs in breast cancer. There is also the role of the *HLF* gene, which is involved in immune response and which could be at the root of the loss in immunity after chemotherapy.

Predicting the effectiveness of immunotherapies

Immunotherapy is among the treatments most likely to benefit from what personalised medicine can offer. Rather than targeting cancer cells directly, the treatment stimulates the immune system's anti-tumour response. Gains in survival rates have already been shown for more than twenty-five different types of cancer. Immunotherapies also offer useful alternatives for cancers which are resistant to other treatments, as well as for patients in relapse.

However, this approach does have its limits. Immunotherapies are much better tolerated than chemotherapies, but they still generate side effects of an autoimmune nature which can be severe. In addition, some patients who were at first receptive go on to develop resistances. However, as Laurence Zitvogel, director of the Anti-tumour Immunology and Cancer Immunotherapy Unit (ITIC – Univ. Paris-Saclay, Gustave Roussy, Inserm) explains, “In some patients, the cancer regresses and sometimes disappears completely and permanently. Now the goal is to increase the number of patients who could benefit from these treatments. To achieve this, we need to understand why it does

not work with some patients and develop combinations which will optimise the effect.”

To identify the immunological profile of each tumour, Professor Zitvogel’s team is using the ‘in vitro’ approach, which is a combination of ‘in situ’ and ‘in vitro’. It is ‘in situ’ because the tissues analysed come from patients who have already received immunotherapy. It is ‘in vitro’ because these samples are then stimulated using a variety of immunomodulators. The identification of the molecules released by the tumour cells then provides valuable information on the effects of different combinations of immunotherapies, as well as possible resistance. These results are a first step towards the development of predictive tests for the effectiveness of different treatment options.

Visualising gene activity



The development of high throughput DNA sequencing has propelled molecular biology into the field of data sciences and as a result has accelerated its computerization. The need to better visualise information from gene expression reads led to the creation of MULTILAYER. This open-source software has been developed by Marco Mendoza-Parra, a researcher at the Metabolic Genomics laboratory of Genoscope (Univ. Paris-Saclay, Univ. d’Évry, CNRS, CEA). “Our tool makes it possible to better exploit data on gene activity and their location,” he explains. This type of readout, known as “spatial transcriptomics”, is derived from the capture of messenger RNA by a large number of DNA probes, the positions of which are mapped.

By entrusting the processing of this information to a machine learning program, the software associates the gene activity with the spatial information of the tissue studied. The images produced are made up of “gexels”, a combination of genes and pixels, with a resolution of 100 micrometres, i.e. about ten cells. “Using this approach, information is shown as a continuum, which is totally new,” explains Marco Mendoza-Parra. “Nearby gexels share common features and provide a functional mapping of gene expression.”

This technology is very expensive at the moment due to the high throughput sequencing and the use of DNA probes. In order to overcome this barrier and provide more flexibility, Marco Mendoza-Parra is hoping to move beyond computer analysis by producing the DNA chips needed for these experiments. This new type of visualisation will help to decipher how genes are expressed within tissue complexity and ultimately help to unravel the specific mechanisms of certain pathologies.

Reducing side effects

Understanding the mechanisms of gene expression also provides useful information for tailoring cancer treatments to individual patients. The large doses of X-rays which pass through the tissue to the tumour cells during radiotherapy sometimes cause adverse reactions, which are usually transient and of low intensity. However, 10% to 15% of patients experience much more severe and long-lasting effects. “Healthy tissues surrounding the tumour are also irradiated, including blood vessels, supporting tissues and nearby organs,” explains Michèle Martin from the Laboratory of Genomics and Radiobiology of Keratinopoiesis at the Institute of Cellular and Molecular Radiobiology (IRCM – Univ. Paris-Saclay, Inserm, CEA, Univ. de Paris). “These complications include hypoplasia, a loss of tissue which can lead to necrosis, or conversely hyperplasias, where the tissue reacts and leads to fibrosis.”

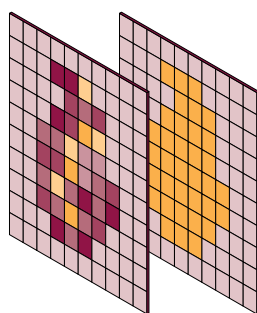

Genetic pathways have been studied to discern what distinguishes radiosensitive patients from others, but so far no specific gene has been identified. “We’ve chosen a different approach, because for us this susceptibility is multiparametric in that it concerns a set of genes,” explains Michèle Martin. “We’re consequently interested in transcriptomes.” The transcriptome approach takes into account the full range of RNAs, whether they code for proteins or play a role in regulatory mechanisms without being translated (non-coding RNAs).

One of the first results of this transcriptome analysis shows an as yet unsuspected alteration of the NFATC2 gene. NFATC2 is involved in apoptosis and cell multiplication. It undergoes a repression of its expression in

radiation-sensitive patients, associated with a process of hypermethylation, a common epigenetic mechanism. For Michèle Martin, “This upstream research aims to lead to clinical tests of radiosensitivity, which are being eagerly awaited by radiotherapists.”

Cancer is a complex disease with often very serious consequences. Beating it completely seems out of reach for the time being. However, the current expansion in personalised medicine is revolutionising treatment options and increasing the chances of remission for a growing number of patients.

Publications

- <https://www.gustaveroussy.fr/fr/prism-ifi>
- Agathe Dubuisson, et al. Immunodynamics of explanted human tumors for immuno-oncology. *EMBO Molecular Medicine*, 13, 2021.
- Julien Moehlin, et al. Inferring biologically relevant molecular tissue substructures by agglomerative clustering of digitized spatial transcriptomes with multilayer. *Cell Systems*, 12, 694-705, 2021.
- Joshua Dulong, et al. NFATC2 Modulates Radiation Sensitivity in Dermal Fibroblasts From Patients With Severe Side Effects of Radiotherapy. *Frontiers in Oncology*, 10, 2020



Title

Sound and light in the fight against cancer

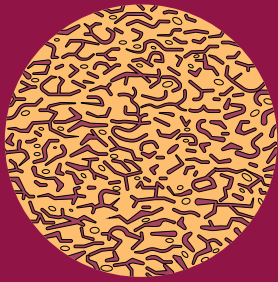

Methods of diagnosing and treating cancer are constantly evolving towards less invasive techniques with fewer side effects. Today, polarised light is used to detect certain tumours. In the very near future, computer simulation will extend the use of focused ultrasound.

The earlier a cancer is detected, the more likely it is to be cured. This is especially true for skin cancers, and melanoma in particular whose tumours metastasise rapidly. However, the current detection technique, which is based on visual observation of suspicious skin patches, is 80% effective. As a result, one in five tumours is not detected in time. Élise Colin-Koeniguer, a research engineer at ONERA Palaiseau and co-founder of the start-up ITAE Medical Research is developing an innovative early diagnosis system. *“The instrument operates by employing the principle of dynamic speckle which has been used for many years to observe microvascularisation,”* explains Élise Colin-Koeniguer. *“Until now, this technique has not been used to detect tumours because of its limited ability to penetrate the skin.”* The term “speckle” refers to the moving spots which can be seen when a laser is shone on a surface. When projected onto the skin, some photons are reflected while others penetrate more deeply.

Detecting tumours under the skin

“Using the polarisation properties of light, we neutralise the surface response to access information deeper down,” continues Élise Colin-Koeniguer. This information is about the movement of blood in the capillaries which supply the tissues. The unusual metabolism of cancer cells leads to the creation of a network of blood vessels to supply them with nutrients and oxygen. *“Together with our colleagues from*

the Institute of Pharmacology and Structural Biology (IPBS) in Toulouse, we’ve shown that our instrument detects this microvascularisation from the first day a tumour appears. There are no other validated systems which provide such early detection as far as I know.” Several working prototypes are currently on loan to partners. *“Six devices are currently in circulation and we’ve had almost no negative feedback on their use,”* points out Élise Colin-Koeniguer. *“The results are still being analysed, but we’ve already proven the viability and reliability of the technique.”*

The next step is to market the device to hospital laboratories. The process is also attracting interest beyond oncology, with offers of collaborations in the area of controlling the vascularisation of organs intended for transplantation. Eventually, approval of the product by the health authorities will unlock the coverage of associated procedures which will allow dermatologists in public practice to access this technology.

Ultrasound which heals

The medical use of ultrasound began in the 1970s with ultrasound scanning, before finding other therapeutic applications like the destruction of blood clots and tumours. Today, High Intensity Focused Ultrasound (HIFU) treatment makes use of the properties of acoustic waves which are focused by “electronic lenses” in the same way that a magnifying glass focuses light rays. *“The input from the different elements of the probe must arrive at the same time at the focal point. The energy is then concentrated in an area the size of a grain of rice,”* explains Sylvain Chatillon, from the Systems and Technology Integration Laboratory (LIST – Univ. Paris-Saclay, CEA). The targeted tissues absorb the energy of the waves, causing them to heat up and the cells to be destroyed.

The safety of low-intensity ultrasound gives these applications the status of minimally invasive therapies: collateral effects on neighbouring organs and/or on healthy parts of the treated organ are very limited. This therapy is particularly suitable for easily accessible tumours located in soft tissue where ultrasound propagates well. *“This is the case for prostate cancer, for example,”* says Sylvain Chatillon. *“However, it’s more difficult for the waves to travel if they encounter obstacles, as bone walls, and their focus becomes more complex.”*

Working towards modular simulation

Adapting HIFU treatment to other situations means modifying the protocols and equipment

currently used. However, as Sylvain Chatillon points out, *“The development of new treatment protocols require very resource-intensive and time-consuming studies before they are approved by the health authorities.”* In view of this, computer simulation offers a valuable aid. The CEA-List’s CIVA Healthcare software platform offers several simulation modules, including some developed in partnership with Inserm. These optimised and tested modules ease the calculation of the transmitted sound field, the local temperature rise and the evaluation of the delivered thermal energy dose, in order to estimate the contour of the produced lesion. The approach helps to take into account the many parameters involved in a treatment protocol, for the purposes of optimisation, sensitivity analysis and performance demonstration.

This approach also applies to the personalisation of treatments. As Sylvain Chatillon points out, *“Variations in patient-specific biological parameters influence the effectiveness of treatments. Our substitution model, built by learning from simulation databases, considers these specificities to provide a real-time patient-dependent simulation. Ultimately, this would lead to the customisation of protocols to optimise therapeutic performance.”*

These innovations increase the chances of detecting and treating cancer. They will not replace current techniques, but will complement them to offer the most effective solutions for treatment in each situation.

Publications

- <https://www.itae.fr/fr/>
- Sylvain Chatillon, et al. Applications of intensive HIFU simulation based on surrogate models using the CIVA HealthCare platform. *Journal of Physics: Conference Series*, 1761, 2020.

Title

The rise of intelligent, connected and autonomous vehicles at Université Paris-Saclay

Vehicles today are equipped with a multitude of features and offer unequalled driving comfort and safety. In a few years, thanks to the technological advances under development, they will probably be able to move around autonomously without a driver.

LABORATORIES AND UNITS LINKED TO UNIVERSITÉ PARIS-SACLAY INVOLVED IN THE FIELD

- 1 – DANTE (Univ. Paris-Saclay, UVSQ)
- 2 – DAVID (Univ. Paris-Saclay, UVSQ)
- 3 – GEEPS (Univ. Paris-Saclay, CentraleSupélec, CNRS, Sorbonne Univ.)
- 4 – IBISC (Univ. Paris-Saclay, Univ. d'Évry)
- 5 – IRT System X
- 6 – L2S (Univ. Paris-Saclay, CNRS, CentraleSupélec)
- 7 – LISN (Univ. Paris-Saclay, CNRS, CentraleSupélec, Inria)
- 8 – LISV (Univ. Paris-Saclay, UVSQ)

- 9 – LIST (Univ. Paris-Saclay, CEA)
- 10 – LMF (Univ. Paris-Saclay, CNRS, ENS Paris-Saclay, Centrale-Supélec, Inria)
- 11 – ONERA

- 12 – SATIE (Univ. Paris-Saclay, CNRS, ENS Paris-Saclay, UGE, CNAM, Univ. Cergy-Pontoise)



Doctoral schools

- Law, Economics, Management (DEM)
- Electrical, Optical, Bio-Physics and Engineering (EOBE)
- Science and Technology of Information and Communication (STIC)

One LabEx involved:

- LabEx Digicosme

Graduate Schools

- Law
- Computer Science
- Engineering and Systems Sciences

Courses linked to the field:

- Master 1 in Electronics, Electrical Energy, Automation (E3A)
- Master 1 and 2 in Network and System Engineering
- Master 1 and 2 in Content, Network, Telecommunications and Systems Security
- Master 2 in Materials, Technology and Components (MATEC):

The main areas of research:

- Automation
- Artificial intelligence
- Component reliability
- Cybersecurity/ software validation

- photovoltaics – electric cars
- Master 2 in Physics and Energy Engineering (PIE): electrical systems for energy and transport
- Master 2 in Robotics, Support and Mobility
- Master 2 in Automatic Mobile Systems
- Master 2 in Embedded Systems and Information Processing

- Electronics
- Energy
- Human factors
- Legislative and regulatory frameworks
- Mechanics
- Mechatronics

- Master 2 in Intelligent Automotive and Aeronautical Systems
- Project strand “Intelligent vehicles” in the first and second year of the engineering course at Centrale-Supélec
- Topic strand in the second year of the engineering course at CentraleSupélec – Autonomous and connected vehicles

- Onboard electronics
- Robotics and control
- Sensors and signal and image processing
- Telecommunication
- Vehicle communication

Some industrial partners:

Renault (Versailles), PSA, RATP, EasyMile, VÉDÉCOM, VALEO...

Key events taking place on the Saclay plateau:

- The DASSAULT UAV Challenge
- The Autonomous Racing Car



Designing autonomous functions...

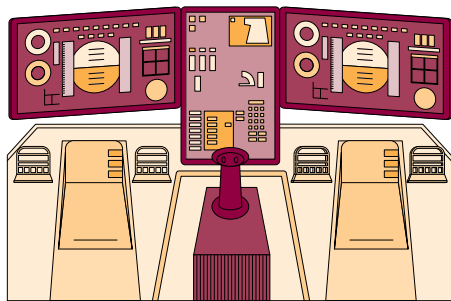

The era of driverless vehicles is fast approaching. Scientific research is at the forefront and is engaged in developing robust and user-friendly automated equipment. The French National Aerospace Research Centre (ONERA) is leading the 'Helicopters' programme in partnership with its German counterpart, the 'Deutsches Zentrum für Luft und Raumfahrt' to meet both civilian and military demand. As part of the 'Intelligent Helicopters' project, they are optimising flight comfort and safety by designing pilot assistance systems. "We're designing control laws for use with control stick haptic feedback systems, hazardous flight condition detection systems, engine failure landing aids and deck landing aids," explains Arnaud Le Pape, who directs the Helicopter programme at ONERA in Palaiseau. Before assessing these features in full flight, the scientists are testing them using flight simulators and with the help of pilots from the French Directorate General of Armaments (DGA). They are not just looking at the interface developed, but also human behaviour towards these new features. However, an autonomous helicopter is not yet a reality. "We're still facing safety issues regarding full autonomy," discloses Arnaud Le Pape.

<https://www.onera.fr/fr/aeronautique/direction-de-programme-helicopteres>

... To prepare for full autonomy

The market for autonomous cars, which is being targeted by many investors, is booming. This is particularly noticeable amongst new start-ups such as Alkalee. This fledgling company, which designs software for centralising automation functions, is the result of a collaboration in 2020 between the Systems and Technology Integration Laboratory (LIST – Univ. Paris-Saclay, CEA) and Renault. "A vehicle today is made up of a hundred or so on-board computers, each of which manages a particular

function, such as the lighting or the car radio," explains Raphaël David, co-founder and CEO of Alkalee. This profusion, which is costly in terms of space, slows down the design of vehicles. "You have to add a processor each time you add a function." However, thanks to Euphilia and Receef (two software programs designed and marketed by Alkalee), the centralisation of and communication between the hundreds of on-board features is ensured. "Adding a new function now only requires an additional algorithm," explains Raphaël David. Features will be constantly updated and any which have become obsolete will be eliminated.

<https://alkalee.fr/>

Monitoring the reliability of autonomous vehicles

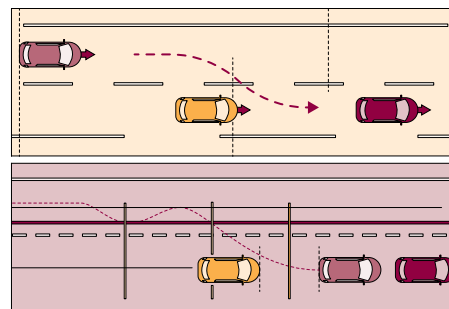

Although the systems designed are robust, manufacturers subject autonomous vehicles to numerous safety tests covering millions of kilometres. Digital simulations are more economical in terms of time and money, and are in great demand for this type of study. This is the aim of the 3SA "Simulation for the safety of autonomous vehicle systems" project being led by the Technology Research Institute IRT SystemX, which is also involving several academic partners (CEA, National Laboratory of Metrology and Testing) and industrial partners (Apsys, AVsimulation, Expleo, Oktal-SE, Renault Group, SECTOR Group, Stellantis, Valeo). This project aims to use digital simulation to monitor the safety of autonomous vehicles until 2023. To this end, the team of scientists is defining and modelling the on-board sensors, the event detection and decision making processes in order to assess the risks involved with autonomous behaviour. "One thesis is seeking to define standard behaviours in order to assess the safety of the decision made by the vehicle," adds Vincent Honnet, who is project manager at IRT SystemX. To simulate risky situations, the team incorporates realistic scenarios, sometimes involving the behaviour of nearby motorists. The modelling of this

human factor is the subject of another joint public-private thesis.

<https://www.irt-systemx.fr/projets/3sa/>

Working towards more sustainable transport

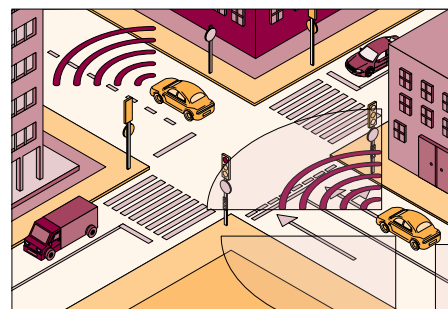

"What will autonomy bring to urban transport?" This important question is at the heart of the research being carried out by Dominique Barth's team at the Data and Algorithms for a Smart and Sustainable City laboratory (DAVID – Univ. Paris-Saclay, UVSQ). According to the researcher, the main benefits of autonomous vehicles are their responsiveness and sustainability. "They can adapt to the needs of users," says the researcher, who is also director of the laboratory and leads the "New Mobility and Shared Energy Solutions" committee at the Institut Védécom – the French public-private partnership research and training institute dedicated to sustainable mobility. The team is focusing its research on transport services. It is studying the dynamic management of autonomous taxis and shuttles in large cities through two theses being carried out in collaboration with Védécom. Using real data from Porto, New York and Stockholm, the scientists can simulate scenarios involving over 200 vehicles and their users. Thanks to machine learning, they are developing a programme which can respond quickly to consumer demands while minimising cost. "However, it's difficult to model the uses of a system which has not yet been deployed," points out Dominique Barth. To overcome this, a CIFRE thesis carried out in collaboration with the urban community of Saint-Quentin-en-Yvelines is looking into the recent deployment of an autonomous bus route in the area.

Title

Making mental illness visible – a challenge for MRI

ISEULT MRI

- 1 – Satellite
- 2 – Vacuum chamber
- 3 – Vacuum
- 4 – Helium chamber
- 5 – Active shielding
- 6 – Radio frequency antenna
- 7 – Main coil

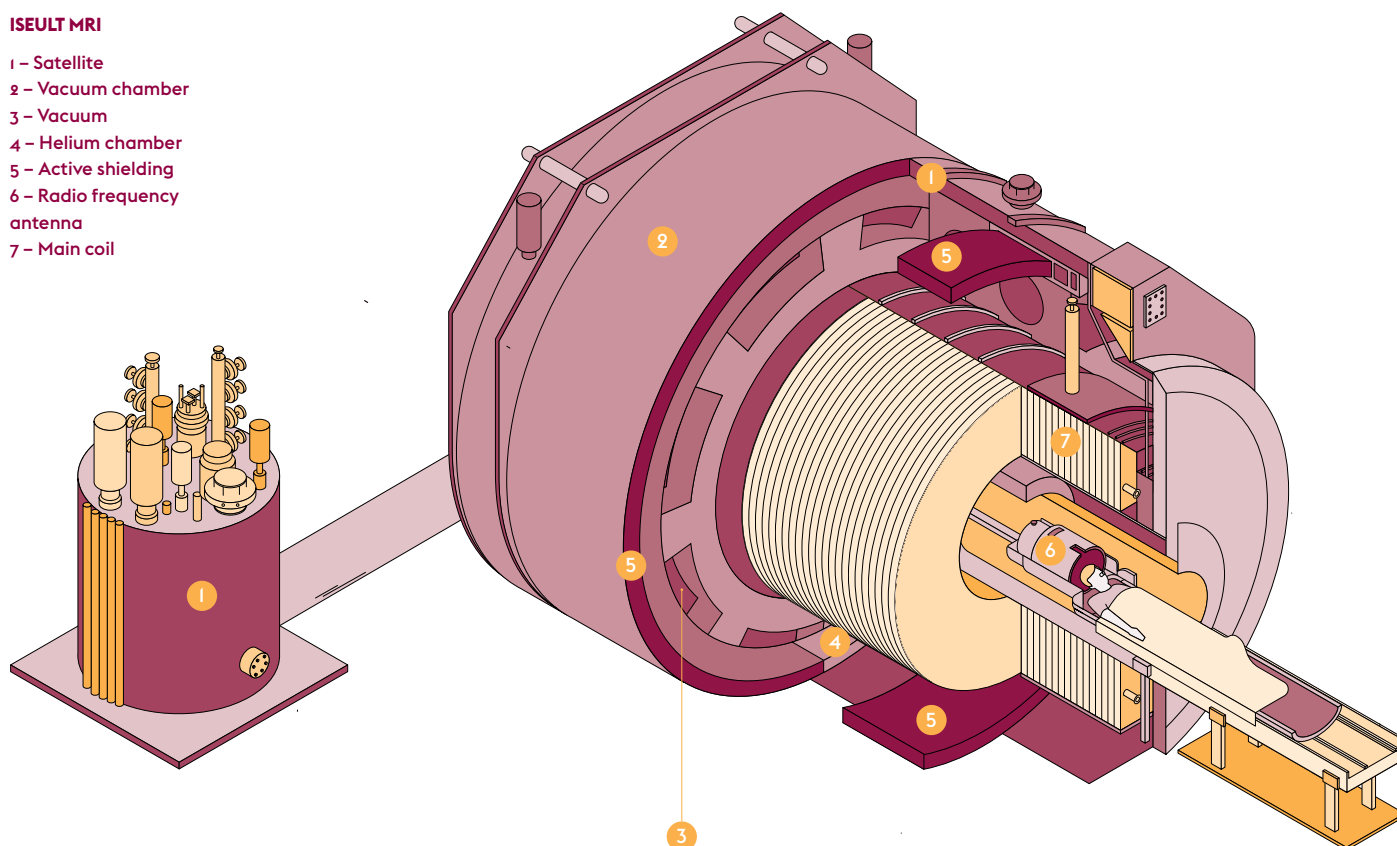

To aid research into mental health, scientists at Université Paris-Saclay are investigating how the human brain functions using more efficient and specialised imaging equipment augmented by artificial intelligence.

The principle of MRI scanning, for which researchers Paul Lauterbur (from America) and Peter Mansfield (from the UK) were awarded the Nobel Prize for Medicine in 2003, is based on the phenomenon of magnetic resonance associated with the magnetic properties of certain atoms – and the hydrogen nucleus in particular. These nuclei point in the same direction when placed in a magnetic field generated by powerful superconducting magnets. Radio frequency pulses are then used to disturb them, much in the same way as a flick of a wrist would destabilise a spinning top without making it fall. The nuclei accumulate energy, which is released when the stimulation is stopped and they return to their original alignment. This signal is picked up by receiving antennas and interpreted to produce two or three dimensional images.

Hydrogen is present in large quantities in the human body and can be largely found in water molecules. It is the H in H₂O. The more hydrogen a tissue contains, the more effective the MRI scans. As the brain comprises 80% water, this technology is most frequently used to study its anatomy and how it functions. Compared to other non-invasive imaging techniques, MRI scans better identify tissues with a differing composition. They also have the advantage of not emitting ionising radiation, unlike X-rays or CT scans. MRI scanning is complex and still expensive. However, it is now benefiting from an opportune combination of recently successfully concluded techniques which will be able to help with mental health research.

Iseult – a 132-tonne newborn

The last quarter of 2021 has culminated in a major event, namely the release of the first images from the Franco-German Iseult MRI project. This is the world's most powerful MRI scanner for human imaging, which started operation in 2017 at the NeuroSpin centre (Univ. Paris-Saclay, CEA) at CEA Saclay. The instrument is the result of an international cooperation between academic and industrial partners which began in 2006 (CEA, the University

of Freiburg, Bruker Biospin, Alstom now part of General Electric, Guerbet and Siemens Healthineers). Images have been released of a pumpkin, chosen for its water content and texture similar to the human brain, with a resolution of 400 microns in all three dimensions. Although even more powerful MRI scanners are already in use for research into materials science, preclinical research on small animals and in industry, most hospital equipment operates at a magnetic field of between 1.5 and 3 Teslas (T). The Iseult MRI scanner, with its 11.7 T, aims to increase the resolution of images currently produced in medical brain research by a factor of ten to one tenth of a millimetre and to reduce the time required to create the image. With all this taken into consideration, the quality of the images obtained from the test on the pumpkin was a good sign.

The production of such a magnetic field (equivalent to 230,000 times the Earth's magnetic field) requires machinery of immense dimensions. It weighs 132 tonnes, is 5 metres in length and 5 metres in diameter and has a central tunnel measuring 90 centimetres in diameter. The heart of this device is a superconducting coil, formed by 182 kilometres of cables wound in rings and cooled to -271.35°C by “superfluid” helium.

This extraordinary MRI scanner will undergo several improvements over the next few months to reach a resolution of 100 to 200 microns, before it is put into service and the first images are taken from a human being. The European Aroma project, which began in 2012, aims to develop a methodology which will result in the optimal operation of the scanner. Lastly, authorisation from health authorities will give the green light for use in research into cognitive science and brain disorders.

kT-points used for fuzzy MRI images

However, increasing the magnetic field can create new problems, such as visual artefacts which degrade the image quality. These adverse effects are a direct result of the increased frequency of the radio-frequency excitation pulses used in high-field MRI scanners. At 3 T, their useful frequency is 125 MHz. It is 300 MHz at 7 T and reaches 500 MHz at 11.7 T. The wavelength is inversely proportional to the frequency, i.e. one decreases as the other increases. When the wavelength used becomes smaller than the object observed, artefacts start to appear. Alexis Amadon and his team at the Building large instruments for neuroimaging: from population imaging to ultra-high magnetic fields unit (BAOBAB – Univ. Paris-Saclay, CEA, CNRS) at NeuroSpin have wrestled with this problem. *“In the case of a 7 T MRI scanner, the wavelength of the pulses used (about 12 cm) is smaller than the average size of the brain. Areas of shade can be seen on the images as well as a loss of contrast.”* This loss of contrast is particularly vexing when studying the human brain as it is divided into white and grey matter.

Alexis Amadon became interested in developing technical solutions to overcome these difficulties. His research resulted in a patent application in 2010 which was filed together with Martjin Cloos, who was a PhD student at the time. The pair had developed a method which ensured a uniform excitation pulse. *“To eliminate artefacts, we interspersed very short pulses with the excitation wave trains,”* explains Alexis Amadon. Called “kT-points”, this transmission method significantly improved the quality of high-field MRI images. This was so much the case that it attracted the attention of Siemens, a leading player in the field of MRI scanners, who intends to implement it on its machines. In the meantime, several clinical studies have already benefited from this technology, including one at 7 T on patients with multiple sclerosis. For the BAOBAB team, the next step is to dispense with the calibration phase prior to the clinical imaging sequences, which would bring undeniable benefits to both

patients and practitioners. The development of technologies to support the increased magnetic fields of MRI scanners is set to continue.

Mood disorders, the mystery treatment

Josselin Houenou, who is director of the psychiatry team at the Clinical and Translational Neuroimaging Research Unit (UNIACT – Univ. Paris-Saclay, CEA) at NeuroSpin, and Fawzi Boumezbear, who is from the BAOBAB team, are both looking into the other possibilities offered by high-field MRI scanners. More powerful MRI scanners permit the detection of elements other than hydrogen, such as carbon, sodium, phosphorus and lithium. As Josselin Houenou points out, *“The mechanism of action of lithium is largely unknown, even though it has been the standard treatment for the mental condition known as bipolar disorder for over 70 years.”* This chronic, severe psychiatric illness affects 1% of adults. Josselin Houenou’s and Fawzi Boumezbear’s work have revealed an accumulation of lithium in the left hippocampus of bipolar patients under treatment for the first time. These results were obtained thanks to a specific piece of equipment. This was a 7 T MRI scanner suitable for this type of imaging. *“There are very few laboratories in the world which have this type of dedicated equipment. We’re the first in France to make these images at 7 T,”* explains Fawzi Boumezbear.

Being able to pinpoint this element, which is so much less plentiful in the human body, required the development of specialist equipment. At 7 T, the resonance frequency of lithium is 120 MHz, while that of hydrogen is 300 MHz. The same antenna just cannot be used for these two elements. *“The same antenna operating with the same efficiency and sensitivity profile over such a range of frequencies would result in a loss of performance and a higher sensitivity to noise,”* explains Fawzi Boumezbear. For the moment, the mechanism of action of lithium remains unclear. However, as Fawzi Boumezbear points out, *“We now have a tool which allows us to detect the presence of lithium at an anatomical level.”* This will help investigate the cellular, metabolic and genetic modalities of the currently elusive functioning of this treatment.

Psychotic disorders – connections are made

Another possibility in the field of mental health offered by high-field MRI scanners concerns the emergence of psychotic symptoms. A recent study led by Josselin Houenou showed for the first time *“A link between abnormalities in the connections between different areas of the cerebral cortex, access to consciousness and the*

appearance of symptoms, such as delusions or hallucinations.” This result, obtained in particular thanks to experiments using diffusion MRI tractography carried out by a team from the BAOBAB unit, highlighted the bundles of neurons linking different areas of the brain. This recent technique is based on the intracellular movements of water molecules. In a spherical space, these movements occur in all directions equally. However, in nerve fibres the movement is restricted to one direction. By observing the orientation of the movement of intracellular water molecules, scientists can trace the pathways of the connections between brain structures.

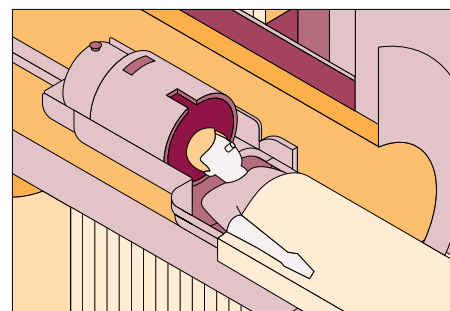

“In bipolar and schizophrenic patients, psychotic symptoms are associated with poorer long-distance connectivity, particularly in the network of conscious access,” explains Josselin Houenou. Members of his team have measured the threshold of conscious perception in healthy control participants, people with a bipolar disorder with or without psychotic symptoms and people with a schizophrenic disorder. To do this, they examined the time between the presentation of a stimulus and its conscious perception. According to Josselin Houenou, *“This threshold is higher in patients showing psychotic symptoms. Auditory verbal hallucinations then occur due to a lack of communication between sensory areas and the integration areas.”*

Artificial neurons for human cognition

The increasing volume and complexity of diffusion MRI data requires new ways of processing the images produced. *“We’re using our expertise in artificial intelligence system design to improve specific measurements from highly complex data,”* explains Demian Wassermann, who is a member of the PARIETAL team (Univ. Paris-Saclay, CEA, Inria) at NeuroSpin. He uses the following analogy to explain his work. *“Can you work out the shape of a drum from the sound it makes? In the same way, we can work out the structure of brain tissue from the magnetic echo generated by its activity.”* Known as the ‘inverse problem’, this approach consists of determining the causes of a phenomenon



from observing its effects. It starts with a modelling stage describing experimentally observable effects, followed by adjustment to this model's parameters as best as possible based on real measurements. However, when applied to brain imaging, this methodology has a limitation. Due to the current nature of MRI, the smallest observable volume corresponds to a cube of about 1.5 mm^3 . Each of these “voxels” (which are equivalent to the pixels making up a digital image) contains several thousand cells. Direct observation of the activity of each of them is therefore impossible. Statistical approximation has to therefore be used, to the detriment of the accuracy of the information obtained.

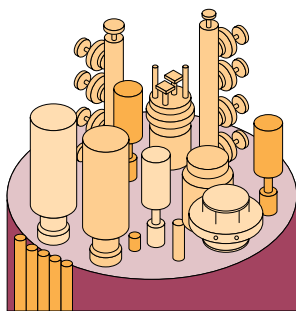

An alternative to this statistical approach is biophysical modelling, based on the spatial characteristics of the elements present in each tissue. However, brain tissue is composed of elements of very different shapes. The somas (cell bodies of neurons) are similar to spheres, while the axons and dendrites which connect them are like long cylinders with a very small diameter. In addition, their distribution in the brain varies significantly, with grey matter containing mostly somas and dendrites, and white matter mostly axons. The complexity of brain structures requires a rethinking of how to use MRI data. “*The techniques available for processing this data were not suitable due to their very high dimensionality,*” concludes Demian Wassermann. Thanks to techniques such as artificial neural networks and machine learning, it is now easier to model how anatomy and cognitive functioning are linked.

Publications

- Quettier L. *et al.* Commissioning completion of the Iseult Whole Body 11.7 T MRI System. *IEEE Transactions on Applied Superconductivity*, 2020, 30 (4).
- Amadon A., Cloos M. Method and apparatus for compensating for B1 inhomogeneity in magnetic resonance imaging by nonselective three-dimensional tailored RF pulses. Patent WO2011128847 (2011).
- Houenou J., Boumezbeur F. *et al.* Accumulation of Lithium in the Hippocampus of Patients With Bipolar Disorder: A Lithium-7 Magnetic Resonance Imaging Study at 7 Tesla. *Biological Psychiatry*, 2020, 88 (5).

• Houenou J. *et al.* Disruption of Conscious Access in Psychosis Is Associated with Altered Structural Brain Connectivity. *Journal of Neuroscience*, 2021, 41 (3).

• Jallais M., Wassermann D. Single Encoding Diffusion MRI: A Probe to Brain Anisotropy. In: *Anisotropy Across Fields and Scales*. (2021).

Title

The limits of neurodevelopment

Technological advances in the field of cognitive science should not lead to mental health being viewed solely from this perspective. This warning has been issued by Bruno Falissard, a psychiatrist and director of the Centre for Research in Epidemiology and Public Health (CESP – Univ. Paris-Saclay, UVSQ, Inserm). “The ‘États Généraux’ (World Conference) on mental health and psychiatry was held in France at the end of September 2021, and the word psychiatry was barely mentioned,” he protests.

As Bruno Falissard points out, “*The role of psychiatry is to deal with people who are suffering with their inner selves. The cognitive science paradigm views the brain as a system which processes data. While this works from a scientific point of view, there’s the risk that patients may be steered away from effective treatment.*” In the case of autism and hyperactivity, there is one aspect which concerns him in particular. This is the rise in a neurodevelopmental approach. “*There’s a growing tendency to consider certain conditions as solely a developmental disorder,*” he points out. “*Policy-making is very receptive to this line of argument.*”

Deviant or different?

To illustrate his point, Bruno Falissard makes a comparison with the changing perception of homosexuality. “*After World War II and up until quite recently, homosexuality was considered a psychiatric illness and an example of deviant behaviour.*” The definition of a “neurodevelopmental disorder” implies an abnormal development of the central nervous system which results in deviant mental functioning. This idea of “deviance” can be understood from a statistical point of view. It is possible to define a standard of homogeneous mental functioning which corresponds to that of a majority of

people, and also, as a consequence, pinpoint those minorities who deviate from it. In the case of autism or hyperactivity, the relevance of this approach can be called into question.

Definitions of these disorders have evolved considerably and now include the idea of a “spectrum” which covers particular mental functions which are often difficult to characterise. Reducing these functions to developmental disorders promotes a simplistic view in that people with different behaviours are solely defined by the abnormal functioning of their brain. Apart from the risk of settling for solutions just involving drugs, this neurodevelopmental approach also denies the fact that today some people claim their situation to be an identity and not an illness. “*It’s not a question of denying the reality of severe autism and the confusion resulting from it. In these cases, the cognitive approach is relevant and allows families to feel less guilty,*” Bruno Falissard points out. “*But covering complex situations with a veneer of rationality carries the risk of treating them poorly. Considering autism as a spectrum is incompatible with the neurodevelopmental approach.*”

While this plea has received positive feedback from the psychiatric community, it also echoes the wishes of a growing number of autistic people who hope not to be cured of their autism, but instead to have the difficulties arising from it properly addressed.

Publications • Falissard B. Did we take the right train in promoting the concept of “Neurodevelopmental disorders”? *European Child Adolescent Psychiatry*, 30 (2021).

Title

James Webb Space Telescope: when astrophysicists see (infra)red

JAMES WEBB SPACE TELESCOPE

- 1 – Primary mirror
of 25 m²
- 2 – Heat shield
- 3 – ISIM module
- 4 – Platform

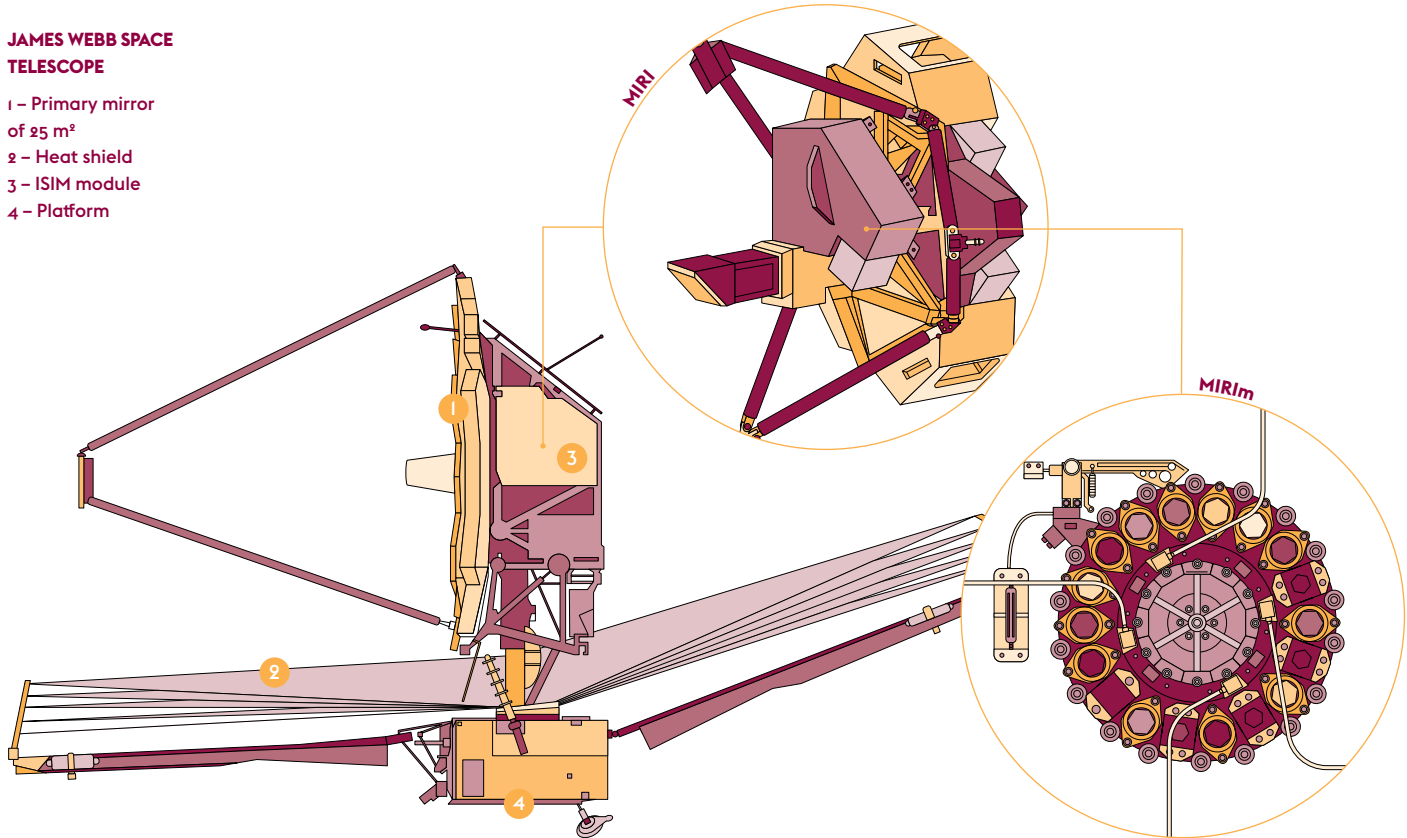

The James Webb Space Telescope, with its staggering dimensions and four on-board scientific instruments, is heading for space with the promise of delivering the most exciting infrared images of the Universe.

By their own admission, the goal of astrophysicists can be summed up in a few words: to see ever more of the radiation coming from the universe and to obtain as much information from it as possible. Space telescopes play an important role in this quest. Unlike ground-based observatories, the fact that these telescopes are in space frees them from the distortion and absorption of radiation caused by the Earth's atmosphere which severely impairs observations.

The James Webb Space Telescope (JWST) is the latest in a 25-year collaboration between the US (NASA), European (ESA) and Canadian (CSA) space agencies. Although it is the successor to the Hubble Space Telescope (HST), which was launched in 1990 to orbit the Earth and which is still in operation, the JWST also follows on from the Spitzer Space Telescope, which was launched in 2003 and

has completed its mission, and with which the JWST also shares the same love for infrared radiation. While the images and spectra recorded by the HST are in the UV, visible and near-infrared range, the JWST will work in the infrared range to wavelengths of 28 microns (μm). This is because the first very distant stars and galaxies can be observed in the infrared range as their radiation has shifted towards the red end of the spectrum as a result of the expansion of the universe. This spectral range reveals the interstellar dust and gas from which new stars and planetary systems form. It also makes it easier to observe exoplanets, which are planets outside the Solar System which orbit a very bright star in the visible spectrum.

Although it has been postponed many times, the JWST is now expected to be launched on 22 December 2021 from the Guiana Space Centre in Kourou. With its 25 m² primary mirror folded in the head of the Ariane 5 rocket fairing, it will be launched towards its future orbital position, the second Lagrangian point (L2) located 1.5 million kilometres behind the Earth in relation to the Sun. It will reach this point after four weeks. In the meantime, the JWST will deploy its huge sunshield and

primary mirror. The shield, which is the size of a tennis court, will protect the telescope from radiation from the Sun, Earth and Moon and keep it as cold as possible - at -233°C or 40 K - to limit stray infrared radiation it emits. The mirror is made from 18 hexagonal panels covered with a thin film of gold which will reflect and focus the radiation to four on-board measuring instruments.

In search of the first light

Once Lagrangian point L2 has been reached and after a testing phase of several months, the telescope and the international teams of scientists will get on with the real business of studying the first stars and galaxies born more than 13 billion years ago, as well as the evolution of galaxies, stars, planetary systems and protoplanetary disks, and conditions for the appearance of life, etc.

The size of the JWST, as well as the performances of its four scientific instruments promise a wealth of discoveries, unlike any previous space observatory. Measuring 6.5 metres in diameter, the JWST has an angular resolution which is about ten times greater than that of the Spitzer Space Telescope and a hundred times greater sensitivity.

Its four instruments, called NIRCam, NIRSpec, NIRISS and MIRI, are housed at the heart of the telescope in the integrated science instrument module (ISIM). The first three operate in the near-infrared range (between 0.6 and 5 μm). NIRCam is a camera and spectral imager. NIRSpec is a multi-object field integral spectrometer and NIRISS is a slitless imager and spectrometer. The MIRI (Mid-InfraRed Instrument) is a spectro-imager operating in the mid-infrared range between 5 and 28 μm .

MIRIm – an imager with three functions

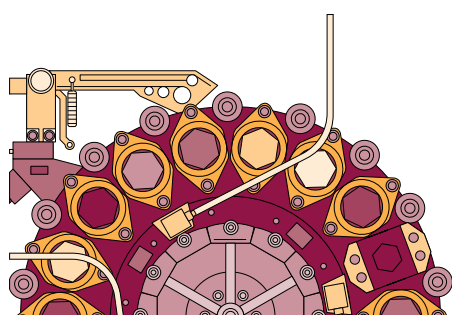

MIRI, which is the result of a collaboration between the United States and Europe, is a little technological gem. It is made up of two distinct elements – a field integral and medium spectral resolution spectrometer (MRS) and an imager (MIRIm). These two sub-instruments share three infrared detectors of the same type, each with 1024 x 1024 pixels. The development of MIRIm was entrusted to a European consortium whose French contribution was led by CEA under the guidance of CNES.

The design, construction and assembly of MIRIm was carried out by the Astrophysics, Instrumentation and Modelling Paris-Saclay Laboratory (AIM – Univ. Paris-Saclay, CNRS, CEA, Univ. de Paris), with the participation of the three technical departments of the Research Institute for the Fundamental Laws of the Universe (Irfu) and three other laboratories in France - the Institute for Space Astrophysics (IAS – Univ. Paris-Saclay, CNRS) in Orsay, the Laboratory for Space Studies and Instrumentation in Astrophysics (LESIA – Observatoire de Paris, CNRS, Sorbonne Univ., Univ. de Paris) in Meudon and the Marseille Astrophysics Laboratory (LAM – CNRS, CNES, Aix-Marseille Univ.) –, as well as partners in Europe.

MIRIm provides three observing modes: an imager mode to photograph space through nine wide-band mid-infrared filters, a low-spectral resolution spectrograph mode to split light into spectra and identify the chemical elements and molecules observed, and a

coronagraph mode to mask the light of a star and observe its close environment.

An innovative design

AIM and IAS have been involved in the project right from the start. The significant amount of responsibility taken on by these laboratories is due to the scientific and technical expertise they acquired during their participation in previous long-wave space missions (ISO, Herschel, Planck, etc.). However, developing an instrument such as MIRI was still a challenge in 1998. This is because this instrument, unlike the others in the JWST, has to be actively cooled to function optimally. “MIRI must reach below 20 K and its infrared detectors must even be at a temperature of 7 K (-266 °C), otherwise a dark current limits observations. Using a liquid helium tank for cooling, as was the case with previous infrared space instruments, would have limited MIRI’s lifetime to a few years,” says Pierre-Olivier Lagage, a researcher at the AIM laboratory and principal investigator (PI) for MIRIm. The active cooling system developed for MIRI, based on closed-cycle machines, is a real technical feat.

“The optical design of MIRIm began in 1998, but it took us five years to construct the instrument’s design because it had to be compact and have only one mechanism. It took us some time to find the solution, which was based on a single filter wheel which was compatible with the three observation modes of MIRIm,” adds Pierre-Olivier Lagage. This wheel has nine spectral filters. These different filters allow radiation to pass through within a given range of wavelengths. “By rotating the wheel in sequence so that each filter is positioned in front of the detector, a set of multispectral images is obtained,” explains Alain Abergel from IAS.

IAS was responsible for designing and developing the telescope’s simulator used for MIRIm optical tests carried out in the AIM laboratory. “Once the instrument was built, its optical features had to be checked to ensure they corresponded to the specifications before delivery,” says Alain Abergel. The team at the AIM laboratory built the test bench comprising a vacuum chamber equipped with a cryostat and a simulator from the JWST. “That was an important step in the project. There was no room for error as once Lagrangian point L2 has been reached, nobody can go and repair the telescope if it needs it!” points out Pierre-Olivier Lagage.

Improving the raw data

In addition to MIRIm developments, the researchers developed innovative algorithmic methods to improve the data produced.

This is because any instrument ‘degrades’ the objects observed, either spatially or spectrally, or by adding noise. “Ideally, the observation of a distant star should give a point. However, in practice, more often than not it results in a larger spot. This is called the point spread function,” explains Pierre-Olivier Lagage. Fundamental in astrophysics, this function stems directly from the physical phenomenon inherent in any camera - i.e. the diffraction of the incident ray at the entrance to the lens. “The larger the telescope, the smaller the spot becomes,” says Pierre-Olivier Lagage. Despite its 6.5 metre diameter and much higher spatial resolution than its predecessors, the ability of the JWST to separate very close points in the sky is still limited. “The image obtained is never perfect. The spatial information is degraded and this is true for any optical instrument,” concludes Alain Abergel. As result, data has to be “unblurred”.

The correction of ‘defective’ pixels from the infrared detectors was another factor to take into consideration. It is statistically proven that a very small number of pixels will not function nominally in each detector. They are much like dead pixels, which remain black in the image, or those affected by cosmic rays which produce outliers. To correct this, the technique of ‘dithering’ is used. This consists of obtaining several images of the same region slightly offset from each other. “We make sure that several different pixels, at least one of which is not ‘defective’, observe the same area,” explains Alain Abergel. By shifting the images very slightly between each shot, super-resolution is also achieved, which improves the spatial information contained and results in a sharper image.

Exoplanets in the sights

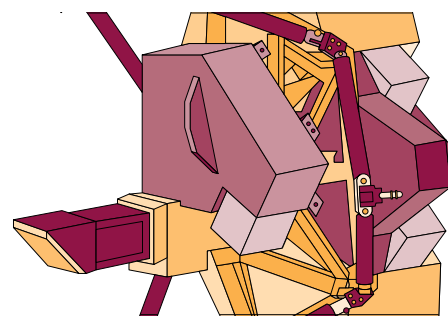

If there is one area of research which has grown over the years, it is that of exoplanets. The first exoplanet was discovered and observed in 1995. Many others subsequently then followed (there are now more than 4,700 of them and their number is growing), so using the JWST to better identify them quickly became an obvious thing to do. The European consortium, which as constructor of



the MIRIm is guaranteed 450 hours of observation, will devote 110 hours to the study of exoplanets. The others programmes will look at protoplanetary disks of dust, extragalactic observations, supernova 1997A and photo-dissociation regions.

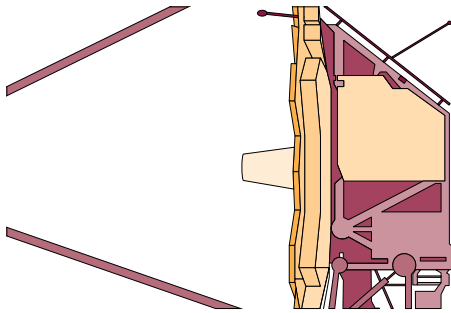

The JWST will focus on writing a new chapter focused on the analysis of the atmosphere of exoplanets. The detection of these planets can be done indirectly thanks to the small variation in the luminosity of a star which they cause when they pass in front of it. However, these variations are sometimes so weak that many other effects dominate and noise overpowers the signal to the detector. The MIRIm's phase mask coronagraph, whose technology was developed at the Meudon Observatory, allows the direct detection of objects in the vicinity of the star by 'turning off' the star itself.

Scientists are looking to see the emission spectrum of these planets to analyse the composition of their atmosphere. "When the planet passes in front of its star on the telescope's line of sight, if it has an atmosphere and molecules are present, these stop the light emitted by the star in distinctive spectral bands which can be identified by the spectrograph," explains Pierre-Olivier Lagage. These molecules, such as water, methane, carbon monoxide or dioxide, phosphine, etc. all have infrared signatures. "The problem is that the James Webb Space Telescope was originally designed to see into the far distance. However, as the observed stars are close, their radiation saturates the images. As a result, a slitless spectroscopy mode has been added to MIRI which reads only a part of the detector," says Pierre-Olivier Lagage. "In the end, the delay in the launch of JWST was used to secure the best methods for analysing the data and to define the best targets to study."

The JWST will be focusing its instruments largely towards the planet TRAPPIST-1 b which orbits its star TRAPPIST-1. This star, located in the Aquarius constellation which is about 40.5 light years from Earth (nearly $4 \cdot 10^{14}$ km) has a planetary system of at least seven rocky exoplanets. Several of them are in the habitable area around the star, which

means water could be present there in a liquid state. "TRAPPIST-1 b is the closest planet to the star and has a temperature of 400 K," says Pierre-Olivier Lagage. But will it be possible to detect biosignatures (those famous signs of the existence of life) on an exoplanet? "The biosignatures could be very different from what we think of today," points out Pierre-Olivier Lagage. "What is certain is that we'll be ready if we observe something abnormal. The range of discoveries made in recent years on exoplanets is such that no matter how many models we have, we are sure that there will be surprises."

A centre of expertise for the community

The MICE centre of expertise created by AIM, IAS, LESIA and LAM and supported by CNES aims to make the knowledge acquired by these teams about MIRI available to the scientific community. "Through a project such as the JWST, the teams working on it develop a genuine expertise with the instrument. This should not be lost once the project is delivered, but should instead be used for other purposes," says Alain Abergel. "The centre will also develop sophisticated methods to improve the data analysis," concludes Pierre-Olivier Lagage. "The best multispectral images from MIRIm will be delivered to astrophysicists," adds Alain Abergel.

The INCLASS joint laboratory set up between IAS and PME ACRI-ST based in Sophie Antipolis specialises in the observation of Earth from space and the development of ground segments. This laboratory will bring complementary skills to the centre of expertise. "Space-based Earth observations face data treatment problems comparable to those of the JWST," explains Alain Abergel. The LabCom, created at the start of May 2021 and which has funding from the ANR lasting four years, aims to develop innovative algorithmic methods for merging imaging and spectroscopy data. "In particular, we hope to extrapolate the spectroscopic information obtained on a small region of the sky by the MRS spectrometer to the wide-field images from MIRIm," explains Alain Abergel.

For the time being, scientists are eagerly awaiting the 'in-flight calibration', or the first tests in real conditions, and then the first astrophysical observations, which should begin by June 2022. The JWST is scheduled to operate for five years (but everyone hopes for twice that) and will be THE large space observatory available to astrophysicists around the world. "The purpose of astronomical observations is to advance our physical understanding of the Universe, and with the JWST we will enter a new world. It's not just

going to be a little better – it will be a hundred times better! The images and spectra provided will be of unprecedented quality and richness. Their interpretation will require the development of highly detailed physical models. That will take years," predicts Alain Abergel.

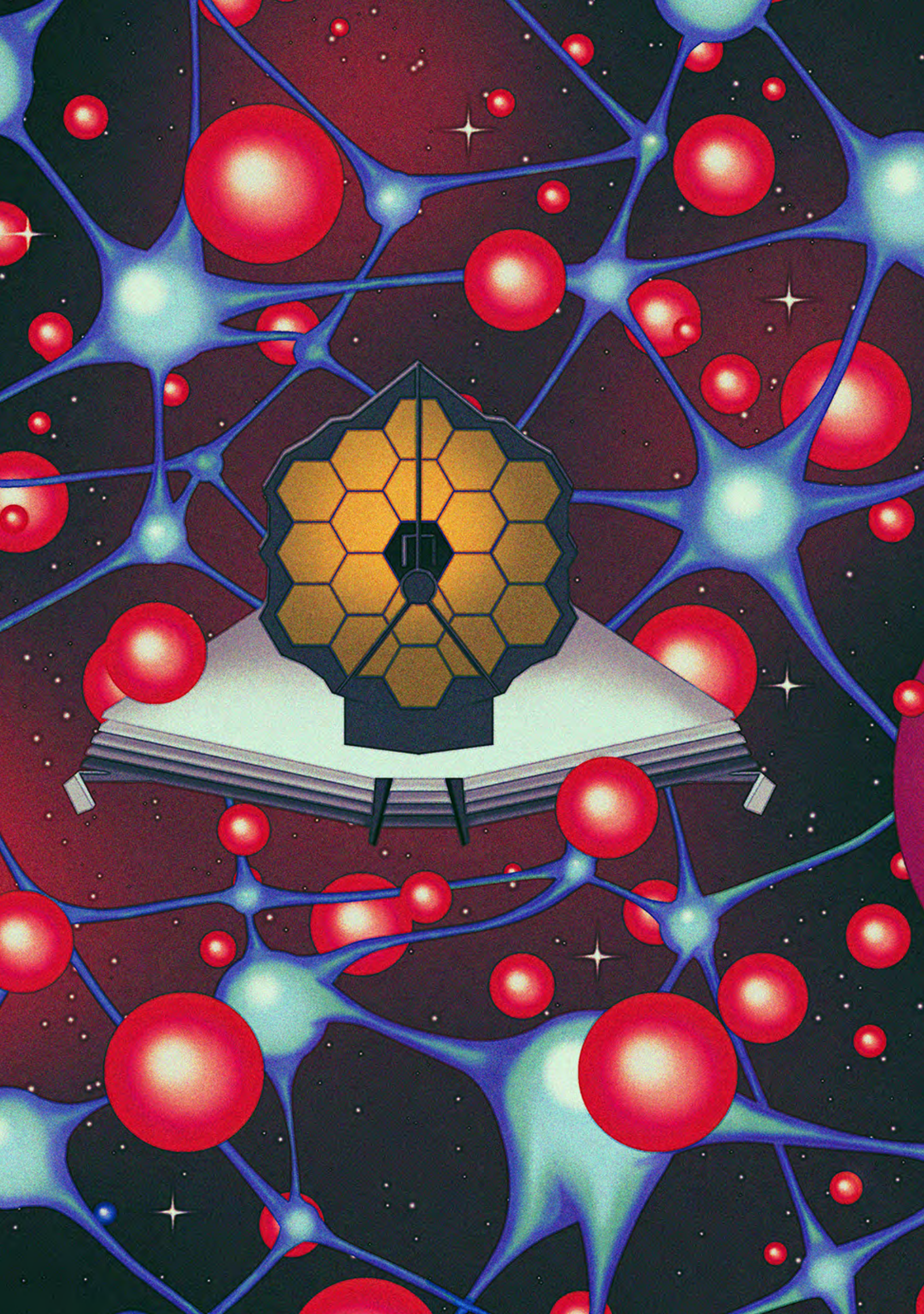

Publications

- M. A. Hadj-Youcef *et al.*, Fast Joint Multiband Reconstruction From Wideband Images Based on Low-Rank Approximation, *IEEE Transactions on Computational Imaging*, vol. 6, pp. 922-933, 2020.
- O. Venot *et al.*, Global Chemistry and Thermal Structure Models for the Hot Jupiter WASP-43b and Predictions for JWST. *The Astrophysical Journal*, vol. 890, 176, 2020.
- P. Bouchet *et al.*, The Mid-Infrared Instrument for the James Webb Space Telescope, III: MIRIM, The MIRI Imager. Publications of the *Astronomical Society of the Pacific*, vol. 127, 953, 2015
- <https://jwst.nasa.gov/content/webbLaunch/index.html>



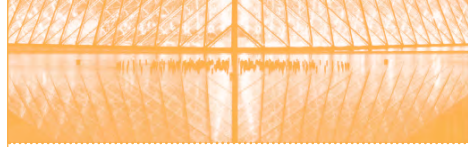

<p>Journal</p> <p>il Giornale</p>	<p>Journal</p> <p>europa press</p>	<p>Journal</p> <p>NEWS MEDICAL LIFE SCIENCES</p>
<p>Title</p> <p>TUMORE DEL POLMONE: ASSOCIAZIONE NIVOLUMAB-CHEMIOTERAPIA AUMENTA SOPRAVVIVENZA</p>	<p>Title</p> <p>DESVELAN EL GENOMA DE MÁS DE 500 MICRO-ORGANISMOS DEL OCÉANO ÁRTICO EN UN ESTUDIO</p>	<p>Title</p> <p>STUDY PAVES THE WAY FOR DEVELOPMENT OF NEW THERAPEUTIC STRATEGIES TO TREAT ADDICTION</p>
<p>I risultati positivi consolidano il miglioramento di efficacia osservato nei trattamenti a base di nivolumab in quattro studi clinici di Fase 3 nei tumori in stadio precoce tra cui il cancro del polmone.</p> <p>https://www.ilgiornale.it/news/salute/tumore-polmone-associazione-nivolumab-chemioterapia-aumenta-1988510.html</p>	 <p>Un equipo de investigadores liderado por el Institut de Ciències del Mar (ICM-CSIC) de Barcelona ha desvelado en un estudio el genoma de más de 500 microorganismos marinos del océano Ártico, de los cuales más del 80% pertenecen a especies desconocidas hasta ahora.</p> <p>https://www.europapress.es/catalunya/noticia-desvelan-genoma-mas-500-microorganismos-oceano-artico-estudio-20211116181626.html</p>	<p>Drug addiction is a psychiatric disorder for which no pharmacological treatment with long-term efficacy currently exists. All addictive substances share the property of raising concentrations of the neurotransmitter dopamine within brain regions forming the neural reward circuit.</p> <p>https://www.news-medical.net/news/20211021/Study-paves-the-way-for-development-of-new-therapeutic-strategies-to-treat-addiction.aspx</p>

<p>Journal</p> <p>THE PIE NEWS</p>	<p>Journal</p> <p>The Washington Post</p>	<p>Journal</p> <p>euronews.</p>
<p>Title</p> <p>FRANCE CLIMBS INTERNATIONAL RANKINGS</p>	<p>Title</p> <p>A HIGH-TECH, LOW-COST PUSH TO TRACK SHARKS, RHINOS AND OTHER SPECIES AMID CLIMATE CHANGE</p>	<p>Title</p> <p>WORLD'S MOST POWERFUL MRI SCANNER DELIVERS ITS FIRST IMAGES – OF THE INSIDE OF A PUMPKIN</p>
 <p>The organisation, which promotes higher education, international student services and international mobility in France, noted that French institutions were doing increasingly well in both the Shanghai and Times Higher Education rankings.</p> <p>https://thepienews.com/news/france-climbs-international-rankings/</p>	<p>Scientists are openly sharing designs for cheaper satellite devices that will help follow millions more animals under stress in the wild.</p> <p>Paul Clerkin makes his living roaming the oceans in search of obscure shark species. At 36, he's already discovered more than a dozen.</p> <p>He has a somewhat different goal with his current target, a mysterious, deep-sea recluse called a megamouth. Clerkin wants to tag one with a tracker and tiny camera to record its every move and shed light on key unknowns about the species.</p> <p>https://www.washingtonpost.com/climate-solutions/2021/10/11/high-tech-low-cost-push-track-sharks-rhinos-other-species-amid-climate-change/</p>	 <p>The world's most powerful MRI scanner, which could have profound implications in diagnosing neurological diseases, has delivered its first images – of a pumpkin.</p> <p>https://www.euronews.com/next/2021/10/08/world-s-most-powerful-mri-scanner-delivers-its-first-images-from-inside-a-pumpkin</p>

Title

Facilities at the disposal of students and staff

Université Paris-Saclay provides numerous facilities on its campuses for the well-being of its student community and its administrative and research staff.

With 230 places in community nurseries, 225 places with childminders, 9 school groups, 2 secondary schools, 1 plan for an international secondary school in the Moulon district and 1 secondary school in the town of Gif-sur-Yvette, children of the University's staff and researchers (including those who are visiting) will certainly have no problems with their education. "We're very proud to welcome Université Paris-Saclay to our town. We're committed to building bridges between students and families and creating a true urban campus," says Caroline Lavarenne, the Deputy Mayor of Gif-sur-Yvette and who is also in charge of Social Affairs, University Relations and Student Life. It is also worth pointing out that the leisure centre at the Orsay Faculty Committee for Social Support (CESFO) is open on Wednesdays and during school holidays for the children of University staff and families working at Orsay town hall.

ENS Paris-Saclay and CentraleSupélec, aware that it is not always easy for students and staff to move during their working hours, have made concierge services available to them through the company ASAP Conciergerie. "We offer haircuts for €12, a weekly delivery of vegetable baskets, car washing and dry cleaning services. If you are interested in one of these services, all you have to do is consult your concierge's* office hours and book the service. You can take the opportunity to visit the mini shop and buy honey or biodegradable coffee capsules," points out Sophie Castelli, founder of ASAP Conciergerie.

For the many talented students and teachers coming from abroad, the 'Science accueil' site provides all the information needed to plan and ensure their travel arrangements. Upon arrival at Université Paris-Saclay, they can also receive help with administrative procedures from GATE (the Foreign Talent Welcome Desk).

* Tuesdays and Fridays in the Sud-Est building at ENS Paris-Saclay, Mondays and Thursdays at desk 2 in the Eiffel building at CentraleSupélec.

<https://www.science-accueil.org/>
<https://gate.paris-saclay.fr/>



© ASAP Conciergerie



© Gif-sur-Yvette town hall

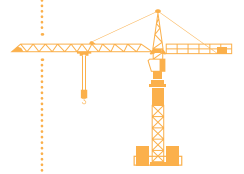

Title

Third call for “Campus Solidarity” projects 2021/2022

The student community and the administrative and research staff of Université Paris-Saclay who have a mature solidarity project, a less precise idea or a desire to get involved in an initiative of this kind, are called upon to submit their application before 9 March 2022, as part of the second committee of the call for projects «Campus Solidaires» (Solidarity Campuses) 2021/2022. Led by Université Paris-Saclay’s Foundations & Patronage Network, this call for projects aims to make campuses more supportive, eco-citizen and open to the territory. The objectives are, for example, to combat isolation, improve equality, promote diversity, encourage academic success, promote sustainable development, support a cause or contribute to local life. The assistance provided to the selected projects includes support for the engineering of the project, promotion and visibility, and funding, which must be shared.

<https://www.fondation.universite-paris-saclay.fr/AAP-campus-solidaires>

© ASAP Conciergerie



Title

Buddy programme: three association projects in the second semester

Three projects led by student associations and aimed at foreign students participating in the Buddy Programme, the sponsorship programme of the Université Paris-Saclay, will be set up in the second half of the school year 2021/2022. ‘Paris c’est d’Art’ (Paris is Art), from the UVSQ’s Chercheurs d’ArTchéologie association, will include a visit to the Rivoli district in Paris with an introduction to art history; ‘Checkpoint international of the Night’n Day 2022’, from the Raid CentraleSupélec association, will organise a stopover during the race where a buffet of dishes from different countries will be an opportunity for exchanges in English; ‘Découverte de Paris’ (Discovering Paris), from the OKB association of the University’s Faculty of Medicine, will propose a visit to the Museum of the History of Medicine and a tour in Paris.

<https://www.universite-paris-saclay.fr/actualites/seconde-edition-de-lappel-projets-buddy-programme-3-projets-pour-2022>

© Gif-sur-Yvette town hall



WE WERE THERE			Date	Location	Host	Date	Location	Host
DECEMBER			until 8 January 2022	Orsay	Université Paris-Saclay	31	Gif-sur-Yvette	Université Paris-Saclay
Date	Location	Host	Title			Title		
9	Gif-sur-Yvette	Université Paris-Saclay, ENS Paris- Saclay	THE EXHIBITION “AU FIL DES ÊTRES VIVANTS, LES VERTÉBRÉS UNE BIODIVERSITÉ VISIBLE” (ALONG THE WAY OF LIVING BEINGS, VERTEBRATES, A VISIBLE BIODIVERSITY)			“SHARE YOUR SCIENCE”: PHOTO COMPETITION		
Title			Description			Description		
LAUNCH OF THE SUSTAINABLE ENERGY INSTITUTE			This exhibition, which can be viewed at the Orsay University Library, includes short illustrated information panels presenting the major verte- brate families from an evolutionary perspective, accompanied by naturalized animals. Guided tours are organised for groups.			This project aims to attract the curiosity of the general public to the life of scientists and laboratories and to show what science is like outside of the media and scientific journals, by revealing its artistic side through the eyes of student scientists who are passionate about their disciplines.		
Description			Description			Description		
Launching session of the Sustainable Energy Institute (IES), held at ENS Paris-Saclay. This new interdisciplinary programme of Université Paris-Saclay will focus on sustainable ways of producing, storing, converting, distributing and using energy, taking into account the related economic and societal aspects.			<p>JANUARY</p>			<p>FEBRUARY</p>		
DECEMBER			Date	Location	Host	Date	Location	Host
13	Palaiseau On-line	DATAIA, Inria, Université Paris-Saclay	6 au 8	Gif-sur-Yvette	La Scène de Recherche	3 to 5	Gif-sur-Yvette	La Scène de Recherche
Title			Title			Title		
3 RD EDITION OF THE DATAIA WORKSHOP “SAFETY & AI”			EFFONDRE-E-S (KNOCKED DOWN)			WORDS AND MUSIC		
Description			Description			Description		
The DATAIA Workshop dedicated to the reliability of artificial intelligence brings together researchers and industrialists from the relevant disciplines to share knowledge and issues in the field, consolidate a locally based research community and pave the way for the construction of joint projects. Throughout the day, presen- tations by academics and industrialists, poster sessions and panel discussions will follow one another.			The show 'Effondré-e-s' is the result of a collaborative work between the director Julien Avril, artists and students of ENS Paris-Saclay in the framework of a collective interdisciplinary project, with the support of the Department of Teaching and Research of Mechanical Engineering.			In 'Words and Music', composer Pedro Garcia Velasquez and director Jacques Osinski, with the ensemble Le Balcon, invent a mixed orchestra of humans and robots.		
https://www.universite-paris-saclay.fr/evenements/dataia-workshop-safety-ai-2021			https://ens-paris-saclay.fr/agenda/effondrees			https://ens-paris-saclay.fr/agenda/words-and-music		
DECEMBER			Date	Location	Host	Date	Location	Host
24	Paris	AgroParisTech	2 to 25	Guyancourt	UVSQ	2 to 25	Guyancourt	UVSQ
Title			Title			Title		
ANNUAL DAY OF THE AGROECOLOGY NETWORK CREATED WITHIN THE FRAMEWORK OF THE BASC LABEX			THE WOMEN'S SOUND LIBRARY			THE WOMEN'S SOUND LIBRARY		
Description			Description			Description		
The morning will be dedicated to a poster session where young researchers will present their work related to the agroecological transition.			The author and scriptwriter Julie Gilbert has decided to create a sound library of women authors and has invited other contemporary women writers to write a monologue that gives a voice to a woman who has marked literary history. Five monologues, written in the first person, are performed by five female actors. The installation consists of a series of telephones where each handset connects the audience with one of the authors.			The author and scriptwriter Julie Gilbert has decided to create a sound library of women authors and has invited other contemporary women writers to write a monologue that gives a voice to a woman who has marked literary history. Five monologues, written in the first person, are performed by five female actors. The installation consists of a series of telephones where each handset connects the audience with one of the authors.		
https://www.universite-paris-saclay.fr/evenements/la-bibliotheque-sonore-des-femmes						https://www.universite-paris-saclay.fr/evenements/la-bibliotheque-sonore-des-femmes		

Contributors to this issue:

Alain Abergel, a researcher at the Institute for Space Astrophysics (IAS – Univ. Paris-Saclay, CNRS)
Ola Alayan, a student currently studying for the 2 SERP+ Master • **Alexis Amadon**, a researcher at the Building large instruments for neuroimaging: from population imaging to ultra-high magnetic fields unit (BAOBAB – Univ. Paris-Saclay, CEA, CNRS) at NeuroSpin • **Fabrice André**, manager of the Molecular Predictors and New Targets in Oncology unit (PMNCO – Univ. Paris-Saclay, Gustave Roussy, Inserm) • **Dominique Barth**, director of the Data and Algorithms for a Smart and Sustainable City laboratory (DAVID – Univ. Paris-Saclay, UVSQ)
Olivier Bos, manager of the Master 1 degree in Economics • **Fawzi Boumezbeur**, a researcher at the Building large instruments for neuroimaging: from population imaging to ultra-high magnetic fields unit (BAOBAB – Univ. Paris-Saclay, CEA, CNRS) at NeuroSpin • **Sophie Castelli**, founder of ASAP Conciergerie • **Sylvain Chatillon**, a researcher at the Systems and Technology Integration Laboratory (LIST – Univ. Paris-Saclay, CEA)
Élise Colin-Koeniguer, a research engineer at ONERA Palaiseau and co-founder of the start-up ITAE Medical Research • **Vincent Correia**, Professor of Public Law at the Jean Monnet Faculty (Law, Economics, Management) of Université Paris-Saclay • **Mathieu Crozet**, manager of the Master 2 degree in Economics • **Raphaël David**, co-founder and CEO of Alkalee • **Bruno Falissard**, director of the Centre for Research in Epidemiology and Public Health (CESP – Univ. Paris-Saclay, UVSQ, Inserm) • **Julie Hérisson**, manager of the Mobility Centre at the Department for International and European Relations at Université Paris-Saclay • **Dailil Ichalal**, a researcher at the Computer Science, Bioinformatics and Complex Systems Laboratory (IBISC – Univ. Paris-Saclay, Univ. d'Évry)
Vincent Honnet, a project manager at IRT SystemX • **Josselin Houenou**, director of the psychiatry team at the Clinical and Translational Neuroimaging Research Unit (UNIACT – Univ. Paris-Saclay, CEA) at NeuroSpin • **Pierre-Olivier Lagage**, a researcher at the Astrophysics, Instrumentation and Modelling Paris-Saclay Laboratory (AIM – Univ. Paris-Saclay, CNRS, CEA, Univ. de Paris) • **Caroline Lavarenne**, the Deputy Mayor of Gif-sur-Yvette in charge of Social Affairs, University Relations and Student Life
Arnaud Le Pape, director of the Helicopter programme at ONERA Palaiseau • **Wendy Mackay**, co-organiser of the CreARThaton and a researcher at the Interdisciplinary Laboratory of Digital Sciences (LISN – Univ. Paris-Saclay, CNRS, CentraleSupélec, Inria) • **Divya Mahdavan**, the Academic Writing Centre's coordinator
Michèle Martin, a researcher at the Laboratory

of Genomics and Radiobiology of Keratinopoiesis at the Institute of Cellular and Molecular Radiobiology (IRCM – Univ. Paris-Saclay, Inserm, CEA, Univ. de Paris) • **Marco Mendoza-Parra**, a researcher at the Metabolic Genomics laboratory of Genoscope (Univ. Paris-Saclay, Univ. d'Évry, CNRS, CEA) • **Reda Nouacer**, a researcher at the Systems and Technology Integration Laboratory (LIST – Univ. Paris-Saclay, CEA) • **Lydie Nouvelière**, a researcher at the Computer Science, Bioinformatics, Complex Systems Laboratory (IBISC – Univ. Paris-Saclay, Univ. d'Évry) • **Hélène Piet-Lahaniér**, a researcher at the Information Processing and Systems Department (DTIS) at ONERA Palaiseau
Eva Renouf, manager of the SERP+ Master • **Cristina Stoica Maniu**, a researcher at the Signals and Systems Laboratory (L2S – Univ. Paris-Saclay, CNRS, CentraleSupélec) • **Coline Thevenard**, a first year student studying for the new LASCALA Erasmus Mundus Master • **Jeanne Turpault**, manager of the Contemporary art and research centre of the Societies association • **Demian Wassermann**, a member of the PARIETAL team (Univ. Paris-Saclay, CEA, Inria) at NeuroSpin
Laurence Zitvogel, director of the Anti-tumour Immunology and Cancer Immunotherapy Unit (ITIC – Univ. Paris-Saclay, Gustave Roussy, Inserm)

Members of the Editorial Board who contributed to this issue:

Delphine Achour-Carbonell • **François Bugeon**
Bruno Chanetz • **Marie Etave** • **Claire Fournio**
Fabrice Gatuingt • **Gaëlle Giraudier** • **Catherine Hordelalay** • **Delphine Joseph** • **Olivier Kahn**
Said Mammar • **Véronique Marracci** • **Vincent Martinet** • **Cécile Mathey** • **Rachel Meallet-Renault**
Cécile Pérol • **Bertrand Poumellec** • **Magalie Quet** • **Léa Remaud** • **Franck Richecoeur** • **Hervé Rivières** • **Nicolas Sabouret** • **Jacqui Shykoff**
Julien Signoles • **Tiina Suomijarvi**

Publishing director: Sylvie Retailleau

Managing editor: Marie-Pauline Gacoin

Editor-in-chief: Véronique Meder

Editing: Maeva Chopard, Claire Gerardin, Victor Haumesser, Véronique Meder, Patricia Muller

Art direction: The Shelf Company

Printing: Stipa

ISSN 2679-4845 (printed) – ISSN 2777-4007 (on-line)

Legal deposit to be published

READING
HIGHLIGHTS

THE CONVERSATION

From the electron to the photon, silicon makes its (second) revolution

Laurent Vivien, researcher at the Centre for nanoscience and nanotechnology (C2N - Univ. Paris-Saclay, CNRS, Univ. de Paris), looks back at the contributions of silicon to photonics, its limits and ways of getting around them. (in French)

<https://theconversation.com/de-lelectron-au-photon-le-silicium-fait-sa-seconde-revolution-161028>

Graphs: Who is afraid of what in France?

Philippe Robert, a sociologist at the Sociological Research Centre on Law and Penal Institutions (CESDIP – Univ. Paris-Saclay, UVSQ, CNRS, Ministry of Justice, Univ. Cergy Pontoise), presents the evolution of the feeling of personal insecurity and security concerns in the Île-de-France region over the past few decades. (in French)

<https://theconversation.com/en-graphiques-qui-a-peur-de-quoi-en-france-172084>

Coupon

SUBSCRIBE FOR FREE



by sending your full name,
postal address and email address to:
ledition@universite-paris-saclay.fr

or by sending this coupon by post to:
Université Paris-Saclay – Direction de la marque
et de la communication
Bâtiment Breguet – 3 rue Joliot-Curie
91190 Gif-sur-Yvette – France

Thank you and enjoy reading!

first name	last name
.....
address	city
.....
postal code	country
.....
email	
.....	

Graduate Schools & Institute of Université Paris-Saclay

Acronym	Number of laboratories	Symbol	Number of master's degrees / doctoral schools
C	25		21
CS			3 1
Chemistry	1 1		3 1
Computer Science			12
GEOSCIENCES	7		7 1
Geosciences, Climat, Environment, Planet	1 3		10 4
P	40		1 4
Physics			10 4
Mathematics			60
ESS			10 4
Engineering and Systems Sciences			10 4
L	9		12
Law			12
HHS			8
Humanities - Heritage Science			7 1
EM			12
Economics & Management			11 1
SPS			8
Sociology and Political Science			4 1
Life Sciences and Health	3 6		37
Life Sciences and Health			3 6
SMFH			17
Sport, Movement, Human Factors			5 1
Public Health	2 1		6 4
Biosphera			37
LSH			37
Health and Drug Sciences			1 1
ISL			26
Institute for the Sciences of Light			1 1
Education	3		29
PH			29
Research and Higher Education			29
RHE	7		14
Research and Higher Education			14
EFE			7

A coordinated set of master's degrees, training programmes, doctoral schools and research activities

- FIELDS
- Science and Engineering
 - Human and Social Sciences
 - Life Sciences and Health